

## A new cast-resin transformer thermal model based on recurrent neural networks

DAVOOD AZIZIAN<sup>1</sup>, MEHDI BIGDELI<sup>2</sup>

<sup>1</sup>*Department of Electrical Engineering, Abhar Branch,  
Islamic Azad University, Abhar, Iran  
e-mail: d.azizian@abhariau.ac.ir  
tel.: +98 9122418353*

<sup>2</sup>*Department of Electrical Engineering, Zanjan Branch,  
Islamic Azad University, Zanjan, Iran  
e-mail: mehdi.bigdeli@iauz.ac.ir*

(Received: 06.03.2016, revised: 19.07.2016)

**Abstract:** Thermal modeling in the transient condition is very important for cast-resin dry-type transformers. In the present research, two novel dynamic thermal models have been introduced for the cast-resin dry-type transformer. These models are based on two artificial neural networks: the Elman recurrent networks (ELRN) and the nonlinear autoregressive model process with exogenous input (NARX). Using the experimental data, the introduced neural network thermal models have been trained. By selecting a typical transformer, the trained thermal models are validated using additional experimental results and the traditional thermal models. It is shown that the introduced neural network based thermal models have a good performance in temperature prediction of the winding and the cooling air in the cast-resin dry-type transformer. The introduced thermal models are more accurate for the temperature analysis of this transformer and they will be trained easily. Finally, the trained and validated thermal models are employed to evaluate the life-time and the reliability of a typical cast-resin dry-type transformer.

**Key words:** cast-resin transformer, dynamics, recurrent neural networks, thermal modeling

### 1. Introduction

In many critical applications such as military and residential areas, transformers must be protected against explosion. Thus, nonflammable insulations (such as Askarel and Epoxy Resins) have been offered to be used in transformers. As the usage of Askarel has been phased out, epoxy resins have proven themselves and are widely used in transformers. Therefore, a cast-resin dry-type transformer [1, 2] has been developed as a nonflammable transformer. While a dry-type transformer lacks any cooling fluid and the life-time of insulating system depends on temperature, the thermal behaviour analysis of the dry-type transformer is crucially important.

Previously, the steady-state thermal modeling for different geometries of the dry-type transformer was introduced in [2-8]. Additionally, it is essential to study the transient thermal behaviour and the life-time of the dry-type transformers; thus, it is helpful to introduce some applicable dynamic models for this purpose. Different life-time and transient thermal models have been presented for oil-immersed transformers [9-13]. There are few researches on dynamic thermal modeling of the dry-type transformers [14-17]. References [14, 15] introduce simplified RC models for the dynamic thermal modeling of the dry-type transformers. Different heuristic algorithms have been employed to estimate the parameters of these RC thermal models. As it has been shown in [15], the simplified models are accurate enough for the thermal modeling of the dry-type transformer. Additionally, some detailed RC thermal models have been presented in [16, 17] for the thermal modeling of the cast-resin dry-type transformer. The RC models that are based on the physical structure of the transformer are accurate enough to analyse the dynamic thermal behaviour of the dry-type transformers. But the accurate thermal modeling of the transformer, especially when the current variation is high, cannot be achieved. Thus, it is needed to introduce some compatible methods to model the dynamic thermal behaviour of the dry-type transformer. Nowadays artificial neural networks (ANN) are widely used for temperature prediction in different problems and phenomena [18-24]. Several ANN based dynamic thermal models have been presented for oil-immersed transformers [21-24].

Consequently, novel dynamic thermal models based on the Elman recurrent networks (ELRN) and the nonlinear autoregressive model process with exogenous input (NARX) for the thermal modeling and temperature prediction of the cast-resin dry-type transformers are introduced in this paper. Employing the measured temperatures, the ANN models have been trained and the predicted temperatures are validated against experimental results, the RC thermal models [15-17] and the classic IEC method [25]. Afterwards, using the trained ANN models, the life-time and reliability of the cast-resin transformer are studied. It is shown that, the introduced ANN models have better efficiency in the temperature prediction of the cast-resin dry-type transformer rather than other traditional methods.

Main contributions and novelties of this paper can be listed as following:

- New and simple ANN based thermal models are introduced for the dynamic thermal modeling of the cast-resin dry-type transformer.
- The results of the introduced models are compared to experimental results, the RC based models, IEC equations and to each other.
- Using the predicted and validated ANN models, the life-time and reliability of the cast-resin transformer have been studied.

## 2. Cast-resin dry-type transformer thermal models

### 2.1. IEC thermal equations

Practically, there are few conventional models that are employed for temperature prediction of dry-type transformers [25, 26]. In these traditional models, if the required experimental

parameters are not accessible then the models cannot be employed. Here, the traditional thermal equations that have been presented by the IEC standard [25] are discussed. It is known that the dynamic behaviour of temperature is similar to a simple exponential equation. Thus, by determination of the initial and the final values of this exponential equation, the winding's temperature rise ( $\theta_w$ ) can be governed at each time ( $t$ ) as given in (1).

$$\theta_w(t) = \theta_{w0} + \theta_{w\infty} \left( 1 - e^{-\frac{t}{\tau}} \right), \quad (1)$$

where:  $\tau$  is the thermal time-constant of a winding,  $\theta_{w0}$  is the initial ( $t = 0$ ) winding temperature rise at the beginning of the time period, and  $\theta_{w\infty}$  is the final (steady-state) winding temperature rise that can be expressed as

$$\theta_{w\infty} = \theta_{wn} K^n, \quad (2)$$

where:  $\theta_{wn}$  is the nominal steady-state winding temperature rise,  $K$  is the load factor (load current/nominal current) and  $n$  is an experimental correction coefficient. IEC standard proposes  $\tau = 0.5-2$  hours and  $n = 1.6$  for dry-type transformers [25].

### 2.2. RC thermal model

A schematic view of a cast-resin transformer is shown in Fig. 1a. Thermal behaviour of the windings can be expressed as (3) [16].

$$\frac{1}{r} \frac{\partial}{\partial r} \left( r \frac{\partial \theta}{\partial r} \right) + \frac{\partial^2 \theta}{\partial z^2} + \frac{q''}{k} = \frac{1}{\alpha} \frac{\partial \theta}{\partial t}, \quad (3)$$

where:  $q''$  is the specific loss density,  $\theta$  is the temperature,  $k$  is the thermal conductivity and  $\alpha$  is the thermal diffusion. Now, assume the solid parts to be divided into a number of cylindrical units that are related to each other by thermal resistances (Fig. 1b).

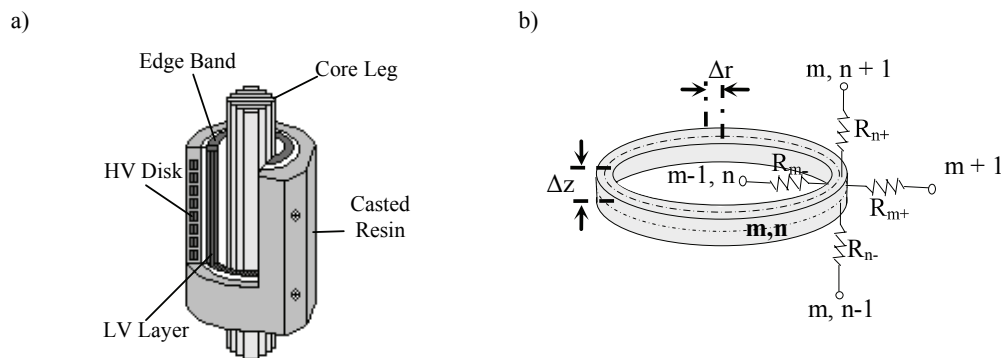

Fig. 1. Cast-resin dry-type transformer: a) schematic view; b) a partial part

In the transient condition, the transferred thermal energy to each unit appears as an increase in the total energy and the unit behaves as an integrated capacitor [16]. If only one unit is selected in the windings and if the heat transfer from horizontal surfaces is neglected (heat transfer is assumed to occur in the radial direction) [2], the thermal behaviour of the winding and the cooling air (on top of the enclosure [27]) can be explained as following [15]:

$$P_w - \frac{\theta_w - \theta_e}{R_w} = C_w \frac{d\theta_w}{dt}, \quad (4)$$

$$P_e - \frac{\theta_e}{R_e} = C_e \frac{d\theta_e}{dt}, \quad \text{where} \quad P_e = \frac{\theta_w - \theta_e}{R_w}, \quad (5)$$

where:  $\theta_w/\theta_e$  are the average temperature rises,  $P_w/P_e$  are the thermal flow sources,  $R_w/R_e$  are the thermal resistances, and  $C_w/C_e$  are the thermal capacitances of the winding/cooling air.

Consequently, (4) and (5) represent a second order RC circuit as given in [15]. Note that  $R_e$ ,  $C_e$  and  $P_w$  are temperature dependent [17]. And  $P_w$  also depends on the load factor and the nominal winding losses ( $P_{wn}$ ) as shown in (6).

$$P_w = P_{wn} K^n. \quad (6)$$

Combining (4)-(6), the matrix form of the thermal model can be explained as (7).

$$\begin{bmatrix} \frac{d\theta_w}{dt} \\ \frac{d\theta_e}{dt} \end{bmatrix} = \begin{bmatrix} -\frac{1}{R_w C_w} & \frac{1}{R_w C_w} \\ \frac{1}{R_w C_e} & -\frac{1}{R_w C_e} - \frac{1}{R_e C_e} \end{bmatrix} \begin{bmatrix} \theta_w \\ \theta_e \end{bmatrix} + \begin{bmatrix} \frac{P_{w0}}{C_w} \\ 0 \end{bmatrix} K^n. \quad (7)$$

Applying the forward Euler discretization rule ( $\dot{\theta} = (\theta[k] - \theta[k-1]) / \Delta t$ ), a discrete time form of (7) can be extracted as:

$$\begin{bmatrix} \theta_w[k] \\ \theta_e[k] \end{bmatrix} = \begin{bmatrix} 1 + \frac{\Delta t}{R_w C_w} & -\frac{\Delta t}{R_w C_w} \\ -\frac{\Delta t}{R_w C_e} & 1 + \frac{\Delta t}{C_e} \left( \frac{1}{R_w} + \frac{1}{R_e} \right) \end{bmatrix}^{-1} \left( \begin{bmatrix} \frac{P_{w0}}{C_w} \\ 0 \end{bmatrix} K^n + \begin{bmatrix} \theta_w[k-1] \\ \theta_e[k-1] \end{bmatrix} \right) = f(K, \theta_w[k-1], \theta_e[k-1]). \quad (8)$$

### 2.3. Novel thermal models based on recurrent neural networks

An artificial neural network (ANN) is a set of interconnected neurons that employs a mathematical model to simulate a biological neural network. ANN is formed by connecting the artificial neurons to each other among adjustable weights. Neural networks can be employed to model complicated interaction between a set of inputs and outputs. ANN can be trained to reach a target output for a specific set of inputs.

In this research, it is assumed that only two nodes in the winding and the cooling air can model the thermal behaviour of the cast-resin dry-type transformer with sufficient accuracy. This means that only the winding's average (or hottest spot) temperature and the cooling air

temperature on top of the winding are important and measurable. Obviously, if the measured cooling air temperature is not accessible, one can neglect the related node and thus the order (number of the outputs) of the thermal model will be reduced. As it can be seen from (8), thermal model needs one input for the load factor ( $K$ ) and two outputs for the winding temperature ( $\theta_w$ ) and the cooling air temperature ( $\theta_e$ ). For more simplification in the thermal model,  $\theta_w$  and  $\theta_e$  are assumed to be temperature rises (absolute temperature - ambient temperature) instead of the absolute temperatures; this helps to remove the ambient temperature from the inputs and to simplify the model.

Note that temperatures are presented in both sides of (8); so the thermal models must have dynamic behaviours. Additionally, the thermal parameters in this equation are temperature dependent and consequently, the thermal model must be able to model the nonlinear behaviour of this system. In order to achieve these goals, two models based on recurrent neural networks are introduced here.

### 2.3.1. Elman recurrent networks (ELRN)

ELRN is a partial recurrent artificial neural network and is a widely used model for dynamic systems modeling. Previously, this network has been employed for temperature prediction in many different problems [18-24]. The ELRN is composed of input, hidden, context, and output layers (Fig. 2).

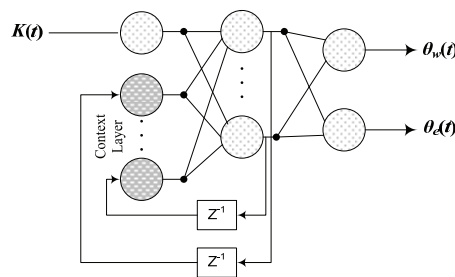

Fig. 2. Structure of the ELRN

The recurrent links in the context layer causes the ELRN to be sensitive to the output's history; dynamic behaviour of the ELRN is provided only by these internal connections. In this research, different training processes were carried out and the optimal number of neurons in the hidden layer (5), type of transfer functions ('logsig' for the hidden layer and 'purelin' for the output layer), the number of epochs, and etc. have been determined using a trial and error process. The network has been trained using the Levenberg-Marquardt method.

### 2.3.2. Nonlinear autoregressive model process with exogenous input (NARX)

NARX is a powerful dynamic neural network for modeling nonlinear and time variant systems. Due to better gradient descent, the NARX learning process is more effective and converges faster than in other artificial neural networks [28]. In modeling long time dependences,

the NARX model is better than other recurrent networks. The NARX networks can be implemented in different ways. A simple way is to use a feed-forward network with delayed inputs in addition to a delayed output link to input (Fig. 3).

A dynamic back-propagation method is required for learning purpose; training may be trapped in local optima. One can use the measured outputs instead of the estimated ones to train the NARX model; thus the feedback links are decoupled. The resultant neural network is a known feed-forward network that could be trained using the classical static back-propagation algorithm. But unfortunately, it was seen that this caused unsuitable results.

In this research, the optimal number of neurons in the hidden layer (5), type of the transfer functions ('logsig' for hidden layer and 'purelin' for output layer), the number of iterations, and etc. have been determined using a trial and error process. The network has been trained using the Levenberg-Marquardt method. In this problem, it has been seen that there was no need for input delays and each output was delayed twice.

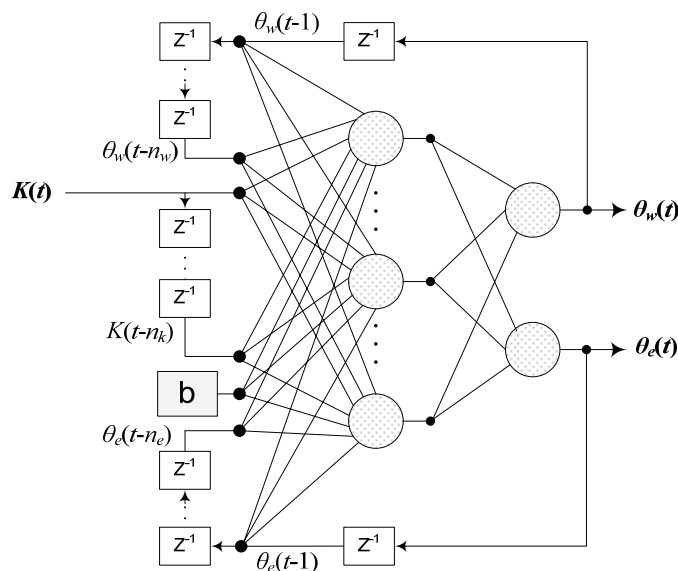

Fig. 3. Structure of the NARX

### 3. Reliability equations for dry-type transformer

Insulation's Life-time in a transformer depends on the winding's temperature. To compute the life-time of a cast-resin dry-type transformer, IEC [9] and IEEE [10] standards proposed some equations. In this research, the expected life-time ( $L$ ) and the failure rate ( $\lambda$ ) of the cast-resin dry-type transformer have been calculated using the following equations [15, 27]:

$$L = \frac{180000}{1875 \times 10^{18}} \times e^{\frac{20475}{1.25(\theta_w + \theta_{amb}) + 273}}, \tag{9}$$

$$\lambda = \frac{1}{L} = \frac{10^{16}}{0.96} \times e^{-\frac{20475}{1.25(\theta_w + \theta_{amb}) + 273}}. \tag{10}$$

The failure rate in (10) depends upon the winding temperature rise and the ambient temperature. The winding temperature is also related to the transformer load.

#### 4. Temperature and life-time evaluation in a typical transformer

In order to train the introduced neural network models, the load cycle of Figure 4 is applied to a typical 400 kVA, 20 KV/400 V transformer [15] and the temperatures of the winding and the cooling air on top of the enclosure [29] are gathered.

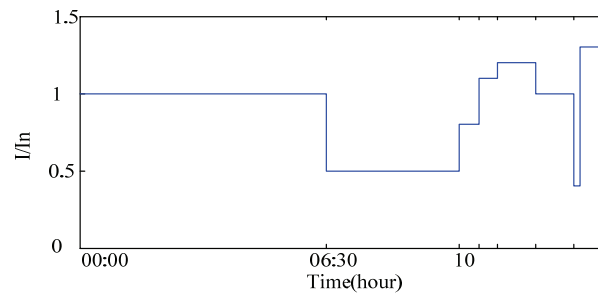

Fig. 4. A Typical load cycle employed for training the neural network models

Using the gathered experimental data, the ELRN and the NARX models have been trained. Figure 5 shows the training process of the ELRN and the NARX neural network models. From this figure, it can be seen that the NARX model is trained faster and has some better performance comparing with the ELRN model.

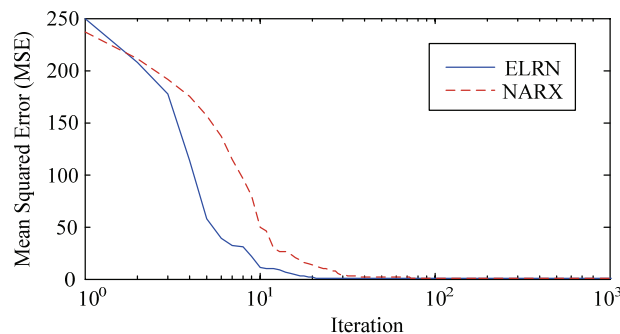

Fig. 5. Training process for neural network thermal models

In the following figures (Figs. 6-8), the predicted temperatures of the introduced neural network models are compared to the results extracted from traditional IEC and RC thermal models. The introduced neural network models are accurate in the thermal modeling of the cast-resin transformer. Note that these models need less information about the structure and the thermal behaviour of the cast-resin dry-type transformer. Unfortunately, the introduced models need gathering more experimental data for training rather than the traditional thermal models. The IEC simple thermal model is implemented easily, but it is not so accurate. The RC thermal model is accurate enough; but while the load variation is too high, the results may not be acceptable. It is seen that the introduced neural network based thermal models are rather more accurate thermal models than the traditional ones. They need no information about the system topology and its physical behaviour. But these thermal models need more gathered experimental data for training purpose.

Finally, using the introduced thermal model, the reliability of the cast-resin transformer can be evaluated according to the load and the ambient temperature variations. Consider a typical operating condition as shown in Fig. 9. By applying the mentioned load and ambient temperature to the introduced thermal model, winding temperature has been predicted as shown in Fig. 10a. Using the predicted winding temperature, the reliability indices can be calculated from (9) and (10) as shown in Fig. 10b.

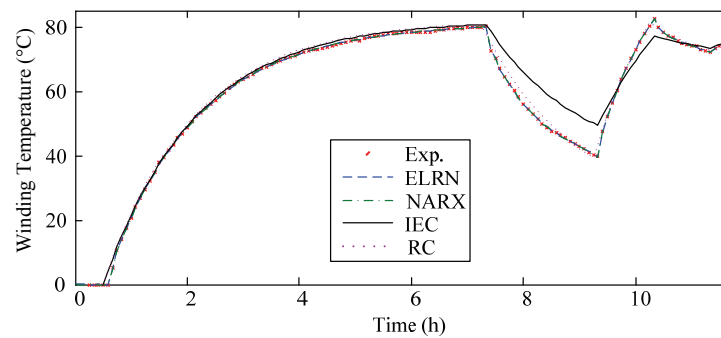

Fig. 6. Predicted winding temperature

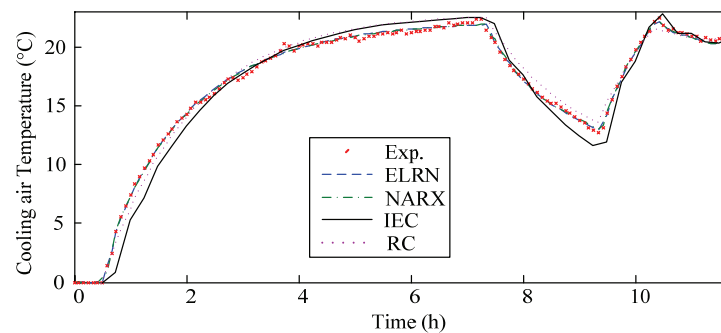

Fig. 7. Predicted cooling air temperature on top of the enclosure



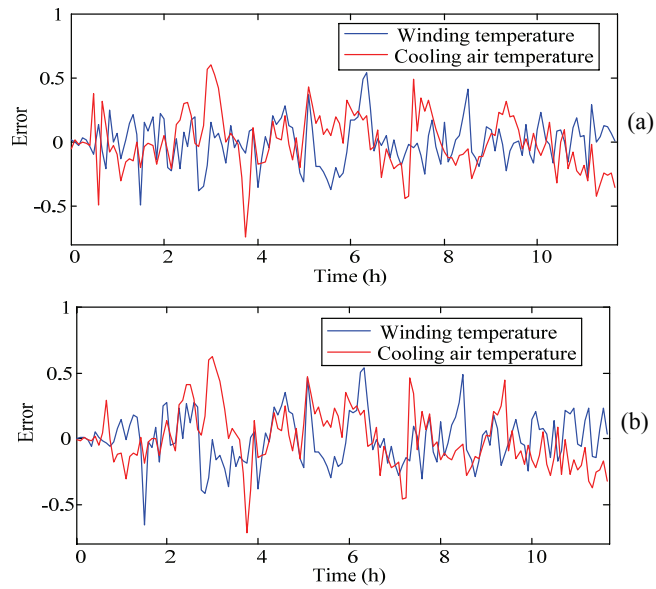

Fig. 8. Error of the predicted temperatures: a) ELRN; b) NARX

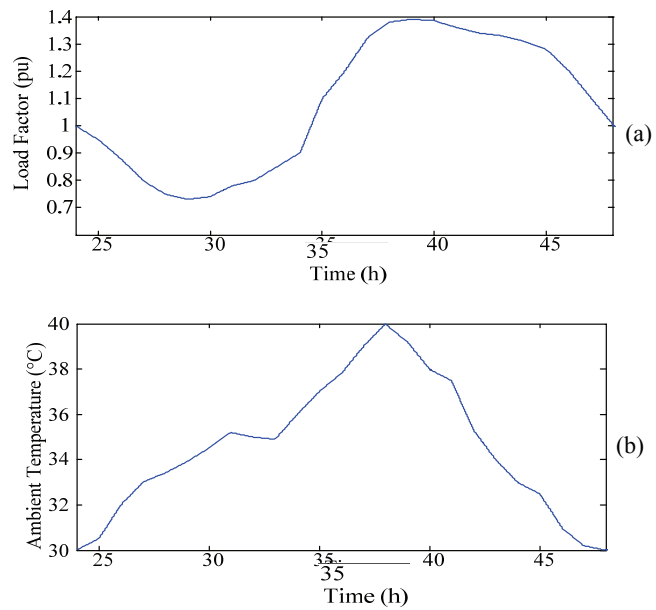

Fig. 9. A typical operating condition: a) load factor; b) ambient temperature variations

One can see that the life-time and the reliability indices of the cast-resin transformer are more sensitive to the load factor and the ambient temperatures while it is compared to the oil-immersed types [9].

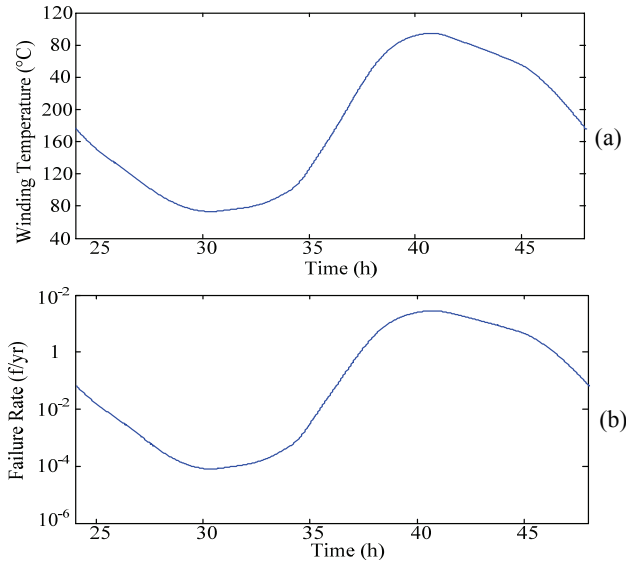

Fig. 10. a) winding temperature; b) failure rate due to variations in load and ambient temperature

It may be so interesting to analyse the effects of load and ambient temperature on the reliability of transformer separately. Fig. 11a shows the effect of load variation and Fig. 11b shows the effect of ambient temperature on the failure rate of the cast-resin dry-type transformer.

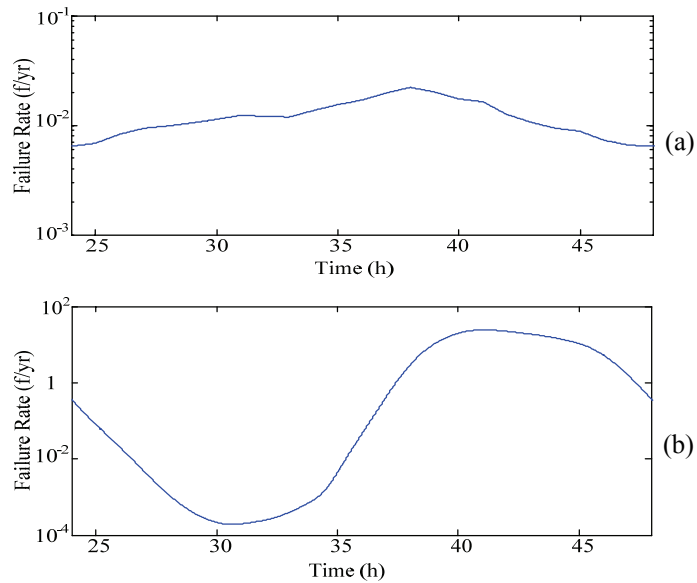

Fig. 11. Transformer failure rate due a variation in: a) load; b) ambient temperature

## 5. Conclusions

The analysis of the dynamic behaviour of the winding and cooling air temperatures is very important in the cast-resin dry-type transformers. Thus in this paper, new dynamic models based on ELRN and NARX neural networks were introduced for the cast-resin transformer thermal modeling. Using the gathered experimental data, the networks have been trained and with the help of additional measurements the accuracy of the thermal models are verified. As it has been presented in this paper, the introduced thermal models show a good performance in the dynamic thermal modeling of the cast-resin transformer.

The IEC equation needs less information about the design parameters of transformer; but it is very simple and it is not an accurate thermal model. The RC thermal model that depends on the physical and actual structure of the transformer is accurate enough. Although the proposed ELRN and NARX models need more data gathering, but their accuracy is higher than the traditional IEC and RC thermal models and need less information about system characteristics. The NARX model has some better training speed when it is training by experimental data.

Finally, by employing the trained and validated thermal models, the reliability indices are analysed. Variation in winding temperature affects the life-time and reliability of the cast-resin dry-type transformer. Some factors that have more effects on the temperature and reliability of the transformer are ambient temperature and load current. In comparison with the oil-immersed types, the life-time of the cast-resin dry-type transformer is more sensitive to the load factor and the ambient temperatures. It was shown that the most serious effect is due to the load current but the ambient temperature also has considerable effects on the life-time of the cast-resin dry-type transformers.

## References

- [1] Azizian D., Bigdeli M., Faiz J., *Design optimization of cast-resin transformer using nature inspired algorithms*, Arabian Journal for Science and Engineering, vol. 41, no. 9, pp. 3491-3500 (2016).
- [2] Rahimpour E., Azizian D., *Analysis of temperature distribution in cast-resin dry-type transformers*, Electrical Engineering, vol. 89, no. 4, pp. 301-309 (2007).
- [3] Pierce L.W., *An investigation of the temperature distribution in cast-resin transformer windings*, IEEE Transaction on Power Delivery, vol. 7, no. 2, pp. 920-926 (1992).
- [4] Lee M., Abdullah H.A., Jofriet J.C., Patel D., Fahrioglu M., *Air temperature effect on thermal models for ventilated dry-type transformers*, Journal of Electrical Power System Research, vol. 81, no. 3, pp. 783-789 (2011).
- [5] Eslamian M., Vahidi B., Eslamian A., *Thermal analysis of cast-resin dry-type transformers*, Journal of Energy Conversion and Management, vol. 52, no. 7, pp. 2479-2488 (2011).
- [6] Dianchun Z., Jiexiang Y., Zhenghua W., *Thermal field and hottest spot of the ventilated dry-type transformer*, IEEE 6th International Conference on Properties and Applications of Dielectric Materials, Xi'an, China (2000).
- [7] Cho H.G., Lee U.Y., Kim S.S., Park Y.D., *The temperature distribution and thermal stress analysis of pole cast resin transformer for power distribution*, IEEE Conference International Symposium on Electrical Insulation, Boston, USA (2002).
- [8] Azizian D., *Windings temperature prediction in split-winding traction transformer*, Turkish Journal of Electrical Engineering and Computer Science, vol. 24, no. 4, pp. 3011-3022 (2016).

- [9] Jian H., Lin C., Zhang S.Y., *Transformer real-time reliability model based on operating conditions*, Journal of Zhejiang University, vol. 8, no. 3, pp. 378-383 (2007).
- [10] Randakovic Z., Feser K.A., *New method for the calculation of hot-spot temperature in power transformers with ONAN cooling*, IEEE Transactions on Power Delivery, vol. 18, no. 4, pp. 1284-1292 (2003).
- [11] Susa D., Palola J., Lehtonen M., Hyvärinen M., *Temperature rises in an OFAF transformer at OFAN cooling mode in service*, IEEE Transactions on Power Delivery, vol. 20, no. 4, pp. 2517-2525 (2005).
- [12] Susa D., Lehtonen M., Nordman H., *Dynamic Thermal Modeling of Distribution Transformers*, IEEE Transactions on Power Delivery, vol. 20, no. 3, pp. 1919-1929 (2005).
- [13] Taghikhani M.A., *Power transformer top oil temperature estimation with GA and PSO methods*, Energy and Power Engineering, vol. 4, no. 1, pp. 41-46 (2012).
- [14] Ghareh M., Sepahi L., *Thermal modeling of dry-transformers and estimating temperature rise*, International Journal of Electrical, Computer, Electronics and Communication Engineering, vol. 2, no. 9, pp. 1789-1790 (2008).
- [15] Azizian D., Bigdeli M., Firuzabad M.F., *A dynamic thermal based reliability model of cast-resin dry-type transformers*, International Conference on Power System Technology, Hangzhou, China (2010).
- [16] Azizian D., Bigdeli M., *Cast-resin dry-type transformer thermal modeling based on particle swarm optimization*, 6th International Workshop on Soft Computing Applications, Timisoara, Romania (2014).
- [17] Azizian D., Bigdeli M., *Application of heuristic methods for dynamic thermal modeling of cast-resin transformer*, International Journal of Advanced Intelligence Paradigms, vol. 8, no. 1, pp. 288-302 (2016).
- [18] Baboo S.S., and Shereef I.K., *An efficient weather forecasting system using artificial neural network*, International Journal of Environmental Science and Development, vol. 1, no. 4, pp. 321-326 (2010).
- [19] Moreno C.J.G., *Using neural networks for simulating and predicting core-end temperatures in electrical generators: power uprate application*, World Journal of Engineering and Technology, vol. 3, no. 1, pp. 1-14 (2015).
- [20] De S.S., Debnath A., *Artificial neural network based prediction of maximum and minimum temperature in the summer monsoon months over India*, Applied Physics Research, vol. 1, no. 2, pp. 37-44 (2009).
- [21] He Q., Si J., Tylavsky D.J., *Prediction of top-oil temperature for transformers using neural networks*, IEEE Transactions on Power Delivery, vol. 15, no. 4, pp. 1205-1211 (2000).
- [22] Assunção T.C.B.N., Silvino J.L., Resende P., *Transformer top-oil temperature modeling and simulation*, World Academy of Science, Engineering and Technology, vol. 2, no. 10, pp. 1115-1120 (2008).
- [23] Alias A.M., George A., Francis A., *Neural network based temperature prediction*, International Journal of Advanced Research in Electrical, Electronics and Instrumentation Engineering, vol. 2, no. 1, pp. 103-110 (2013).
- [24] Smith B.A., McClendon R.W., Hoogenboom G., *Improving air temperature prediction with artificial neural networks*, International Journal of Computer, Control, Quantum and Information Engineering, vol. 1, no. 10, pp. 3100-3107 (2007).
- [25] IEC Std. 60076-12, *IEC Loading Guide for Dry-Type Power Transformers*, (2008).
- [26] ANSI/IEEE C57.96, *IEEE Guide for Loading Dry-Type Distribution and Power Transformers*, (April 1989).
- [27] IEC Std. 60529, *IEC Degree of Protection Provided by Enclosures*, (1989).
- [28] Gao Y., Er M.J., *NARMAX time series model prediction: feed-forward and recurrent fuzzy neural network approaches*, Fuzzy Sets and Systems, vol. 150, no. 2, pp. 331-350 (2005).