

Danuta WIELBIŃSKA and Ewa SKRZYPCZAK

Marine Branch
Institute of Meteorology and Water Management
Waszyngtona 42
81-342 Gdynia, POLAND

Mean air temperatures at definite wind directions in Hornsund, Spitsbergen

ABSTRACT: Observations of wind directions and air temperatures in Hornsund, Spitsbergen, in 1978—1985 were used to compute frequency distribution of wind directions and mean air temperatures at particular wind directions. Prevailing easterly winds (60° , 90° and 120°) resulted in lower air temperatures (to -2.2°C) than winter and spring means and in higher (nearly 1°C) than summer and autumn mean temperatures. Greatest positive deviations from mean seasonal temperatures are observed in winter at southerly and southwesterly winds and reach 10°C . Greatest negative deviations from mean seasonal temperatures are noted at northerly winds (330° and 360°) in autumn and reach -3.7°C .

Key words: Arctic, Spitsbergen, wind direction, air temperature.

Introduction

Local climate of the station in Hornsund, Spitsbergen, indicates a very clear and distinguishable dependence of air temperature from direction of wind just like any other station in the Norwegian Arctic (Steffensen 1982). In the case of Hornsund it is caused by thermal contrasts resulting from location of the station. The station is located in a zone where effect of the warm Gulf Stream from the southwest is modified by this icy archipelago in the north and east, and by the ice-covered Arctic behind it.

This paper presents relation between air temperatures and directions of winds in Hornsund, showing also seasonal variation.

Method and data

Thermal seasons of a year in the Arctic are far from identical with calendar seasons and therefore, in order to show seasonal differences,* the

calculations have been based on bi-monthly periods which can be approximated to thermal seasons observed in Hornsund (Baranowski 1968, Petelski 1981, Stepko and Rodzik *in press*). Spring falls there in May and June, summer in July and August, autumn in September and October and winter in the remaining six months, from November to April. Frequency of wind directions and accompanying mean air temperatures have been calculated for 30° sectors. In the case of very frequent wind directions mean air temperature is based on a large number of data whereas in the case of rare wind directions it is calculated on a respectively smaller number.

Applied materials come from standard meteorological observations carried out during polar expeditions, organized by the Polish Academy of Sciences from July 1957 to August 1958, from July 1978 to July 1981 and from September 1982 to July 1985. General conditions are there illustrated by data from „Statistic tables of selected meteorological elements in Hornsund in 1978—19UB (*unpubl.*).

Frequency of wind directions

Easterly winds are well known to prevail in Hornsund (Statistic tables-*unpubl.*, Stepko and Rodzik 1985, Wielbińska and Minajev *unpubl.*) due both to location within a subpolar zone (in which this direction is a charac-

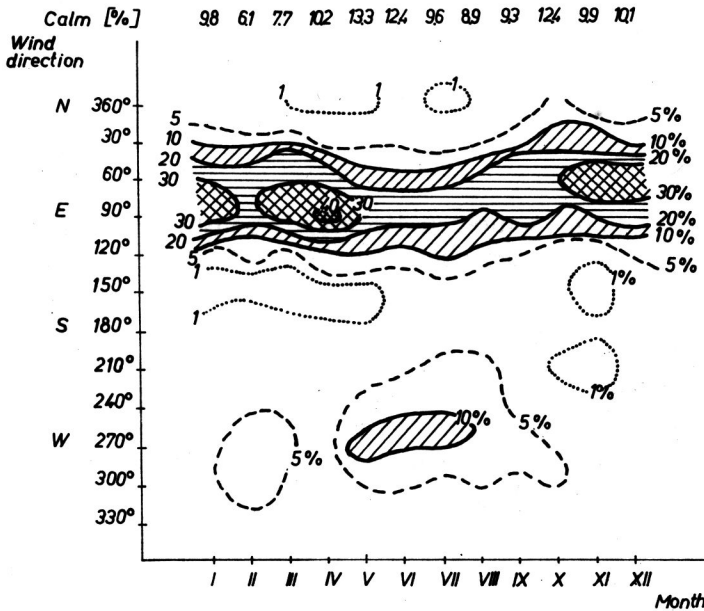

Fig. 1. Annual variation of frequency of wind directions at the Hornsund station in July 1978 — July 1981 and September 1982 — July 1984

Table 1

Annual variation of frequency (in %) of wind direction in Hornsund in July 1978 — July 1981 and September 1982 — July 1984

Direction	Jan	Feb	Mar	Apr	May	Jun	Jul	Aug	Sep	Oct	Nov	Dec	Year
360° (N)	2,1	1,3	1,0	0,4	0,6	2,1	0,2	1,2	2,0	5,6	2,1	2,1	1,6
30°	7,5	5,2	6,2	2,6	2,8	3,0	2,2	3,6	7,6	13,9	14,9	7,8	6,2
60°	30,0	21,9	29,9	21,3	14,2	12,0	12,6	20,5	23,7	29,3	38,0	34,5	23,8
90° (E)	32,1	28,9	36,5	44,2	27,8	24,2	27,8	19,7	30,8	17,2	21,8	24,7	28,1
120°	4,7	6,2	3,9	8,6	9,9	7,8	11,1	6,5	5,1	2,7	1,4	5,3	6,0
150°	0,3	0,7	0,5	0,6	0,7	1,5	3,2	1,6	1,0	1,3	0,2	2,1	1,0
180° (S)	1,8	2,9	1,4	1,0	1,1	1,2	2,3	2,3	1,6	2,1	1,2	2,1	1,7
210°	1,0	3,0	1,3	1,2	3,2	3,2	6,0	6,1	2,5	0,7	0,4	1,4	2,4
240°	1,1	3,7	2,2	2,2	6,6	9,0	9,7	9,8	2,6	1,7	1,3	2,5	4,2
270° (W)	3,8	9,7	5,4	3,4	12,0	11,9	10,3	9,6	6,7	3,9	3,4	2,8	6,5
300°	4,7	8,9	4,3	4,2	6,7	9,3	4,3	6,6	3,9	5,0	4,5	4,7	5,5
330°	1,9	3,2	0,7	1,4	1,6	3,0	1,0	2,3	2,5	3,3	2,1	2,1	1,8
Calm	9,8	6,1	7,7	10,2	13,3	12,4	9,6	8,9	9,3	12,4	9,9	10,1	10,0

teristic feature and results from general atmospheric circulation) and to local reasons (as the fiord has a clear west-east axis what forces such air flow).

Frequency distribution of wind direction for Hornsund, calculated for the incomplete period of 1978—1984 (Table 1 and Fig. 1), shows this predominance and its annual variation. Easterly and northeasterly winds (90° and 60°) occurred during autumn and winter (from September to April) with total frequency from slightly over 45% in October to over 65% in March and April. Winds from these directions were somewhat less frequent from May to August, and in June their total frequency was even lower than 40%. Spring and summer were also quite rich in southeasterly winds with frequencies up to 11%. More frequent than in other seasons, were southwesterly and westerly winds (over 20%), and in June also northwesterly winds (about 10%). Nevertheless, easterly winds prevailed during this season as well with frequencies over 40%.

Variability range of air temperature

Hornsund as located at border of maritime and continental influences, indicates a marked variability of air temperatures, particularly during winter. Temperatures measured at standard synoptic hours in winter, e.g. in January, varied from $+2^\circ\text{C}$ to -33.6°C whereas in summer, e.g. in July, from $+11.3^\circ\text{C}$ to -0.4°C .

Table 2

Probability of occurrence (percentiles) and extreme air temperature (from observations at synoptic hours only) at Hornsund Station in 1978—1984

Month	Highest value			Percentiles					Lowest value		
	$^\circ\text{C}$	year	day	5%	25%	50%	75%	95%	$^\circ\text{C}$	year	day
Jan	2,0	84	01	-0,7	-5,0	-11,9	-17,3	-24,3	-33,6	81	16
Feb	2,0	84	24	0,0	-4,7	-11,2	-18,1	-25,1	-33,4	79	24
Mar	2,9	84	10	-0,4	-6,7	-12,2	-17,4	-22,4	-26,8	81	25
Apr	1,7	84	21	-0,8	-5,7	-10,6	-14,6	-19,5	-25,0	79	17
May	4,4	80	28	1,8	-0,9	-3,8	-7,4	-11,7	-18,4	81	01
Jun	9,3	83	30	4,6	2,5	1,2	-0,5	-2,8	-6,4	83	03
Jul	11,3	83	04	7,1	5,3	4,2	3,2	1,9	-0,4	84	02
Aug	9,8	79	15	6,2	4,6	3,5	2,6	1,1	-0,1	83	26
Sep	6,6	83	10	5,0	3,0	1,2	-0,4	-4,2	-7,3	78	20
Oct	4,6	80	01	2,3	0,0	-3,5	-7,6	-12,5	-16,3	83	27
Nov	3,4	78	08	0,0	-4,0	-9,9	-13,7	-18,9	-27,6	80	25
Dec	1,7	82	30	-1,3	-7,6	-12,7	-17,0	-23,6	-28,8	79	31

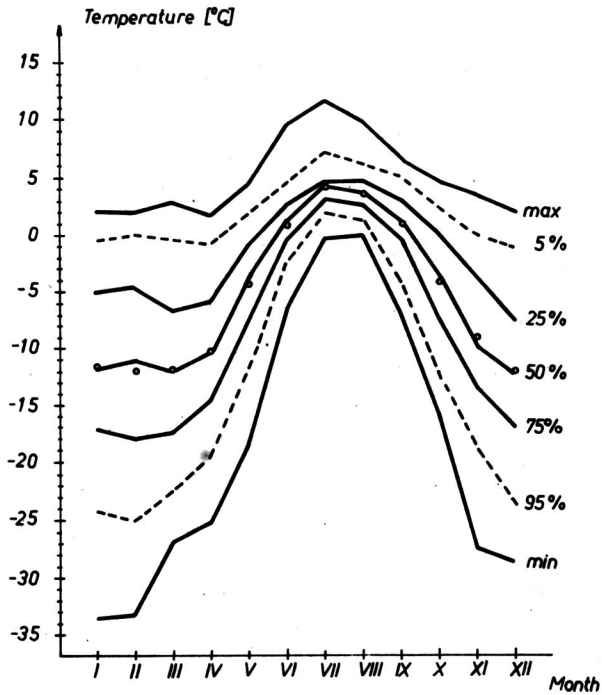

Fig. 2. Variation of temperature at Hornsund station in July 1978 — July 1981 and September 1982 — July 1984 (from measurements at synoptic hours only): maximum and minimum temperature and percentiles of 5, 25, 50, 75 and 95% of occurrence probability. Circles denote monthly means.

Annual variation of frequency distribution of the whole population of temperatures is illustrated by percentiles (probability of occurrence) of 5, 25, 50, 75 and 95% (Table 2 and Fig. 2). When observation period is long enough, the percentiles can be treated as representing the probability of occurrence of a given temperature. Mean monthly temperatures are almost identical with the percentile of 50% (Fig. 2). Values of the latter are confined within the limits from $+4.2^{\circ}\text{C}$ in July to -12.7°C in December. Unfortunately, the season of 1981/82 could not be considered. It had rather low winter temperatures and so, would probably shift mean seasonal temperatures toward lower values.

Relationship between air temperature and wind direction

Mean air temperatures that accompanied defined wind directions have been calculated on the basis of observations carried out every 6 hours.

Also the number of cases in which particular wind directions were observed, are given (Table 3). The same relationships are also illustrated in Figs

Table 3

Mean temperatures \bar{T} (in °C) at particular wind directions in Hornsund. Observations from July 1957 — August 1958, July 1978 — July 1981, October 1982 — July 1984. n — number of observations

Direction	Jan — Feb		Mar — Apr		May — Jun		Jul — Aug		Sep — Oct		Nov — Dec	
	n	\bar{T}	n	\bar{T}	n	\bar{T}	n	\bar{T}	n	\bar{T}	n	\bar{T}
360° (N)	42	-10,4	10	-10,4	15	-1,5	14	4,5	29	-4,6	51	-9,1
30°	128	-12,6	99	-13,2	62	-2,2	68	3,8	185	-2,4	163	-8,6
60°	399	-12,3	414	-12,2	235	-1,7	292	4,4	372	-1,2	469	-11,3
90° (E)	363	-13,2	509	-12,4	349	-2,2	382	4,2	309	-0,3	261	-12,2
120°	64	-12,4	70	-11,6	109	-3,0	137	3,4	44	0,9	139	-10,4
150°	10	-5,7	9	-4,4	10	1,6	40	3,1	21	0,9	16	-10,0
180° (S)	24	-0,8	20	-1,6	14	0,0	39	3,7	32	1,1	30	-4,0
210°	32	-1,7	19	-1,7	41	-0,3	93	3,7	24	0,2	15	-1,1
240°	33	-3,3	38	-2,0	107	0,2	148	3,4	31	0,7	30	-4,1
270° (W)	85	-5,9	58	-4,1	145	-0,1	164	3,9	67	0,1	49	-5,0
300°	77	-10,5	44	-7,1	116	-0,8	83	3,7	52	-2,7	64	-6,6
330°	35	-10,7	18	-8,9	29	0,4	26	4,0	37	-4,9	32	-8,3
Calm	127	-12,7	151	-12,0	235	-0,9	211	3,5	188	-2,3	150	-10,7
Sum	n	1420	1459	1467	1697	1391	1469					
\bar{T}		-11,3	-11,2	-1,3	3,9	-1,2	-10,0					

3a to 3f but there frequency of wind direction is shown in percentage. Mean air temperature for each of be-monthly periods is indicated by a dashed line.

The whole winter season (from November to April) shows generally that mean air temperature was near -11°C (Table 3). During all this time there occurred also warmer periods brought by occasional impact of air from southerly and westerly directions. Increase of temperature during these warmer periods exceeded a mean seasonal temperature by 8°C and more. Mean deviations of temperature at prevailing winter easterly or northeasterly winds are negative and reach -2°C (Table 4).

During the long winter season a certain variation of anemothermal deviations is observed. At the beginning of winter (November and December), air temperatures at southeasterly winds (150°) are not different at all from the mean air temperature, but from January to April air temperatures at these wind directions are higher for about 6°C than the mean. Frequency of these winds is however low and does not allow for generalisations. At the beginning of winter northeasterly winds (30°) of considerable frequency bring also air at higher temperatures than mean air temperature of the season, but during remaining winter months (January to April), such air is much colder (Figs. 3a-c). In January and February, i.e. in mid-winter, the

A

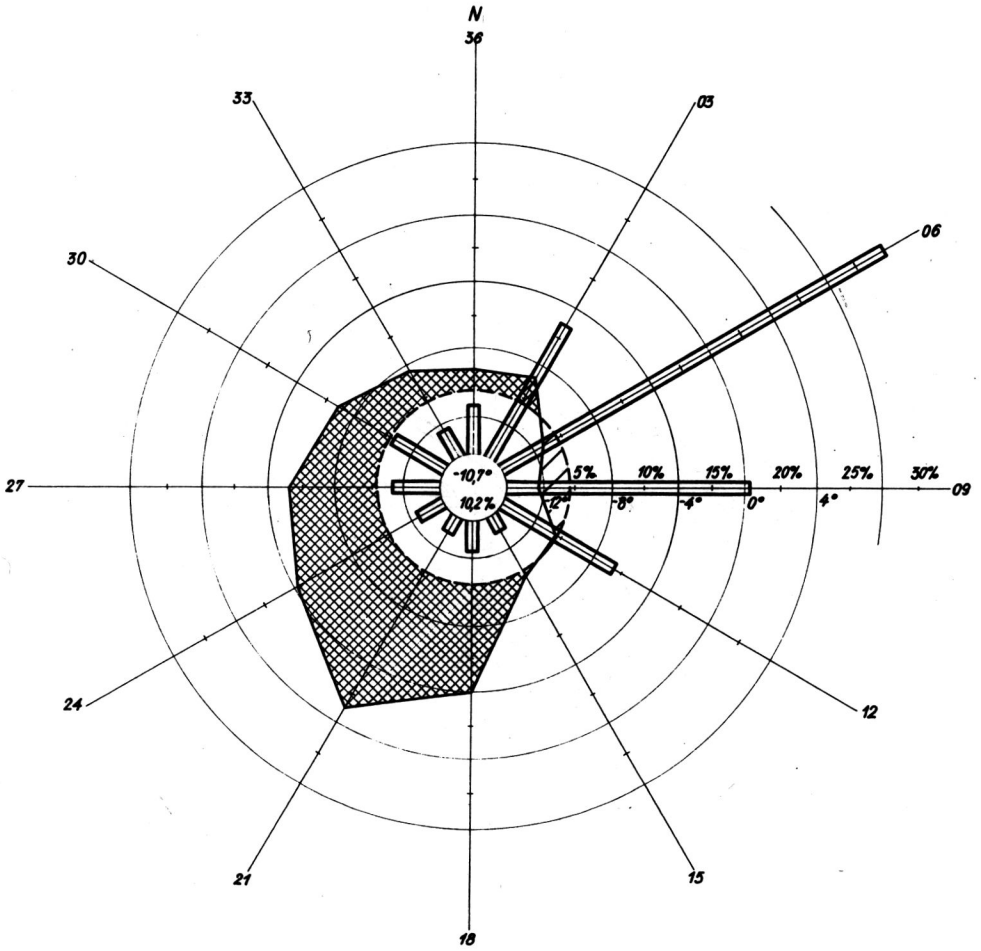

Fig. 3.

For explanations see: F

B

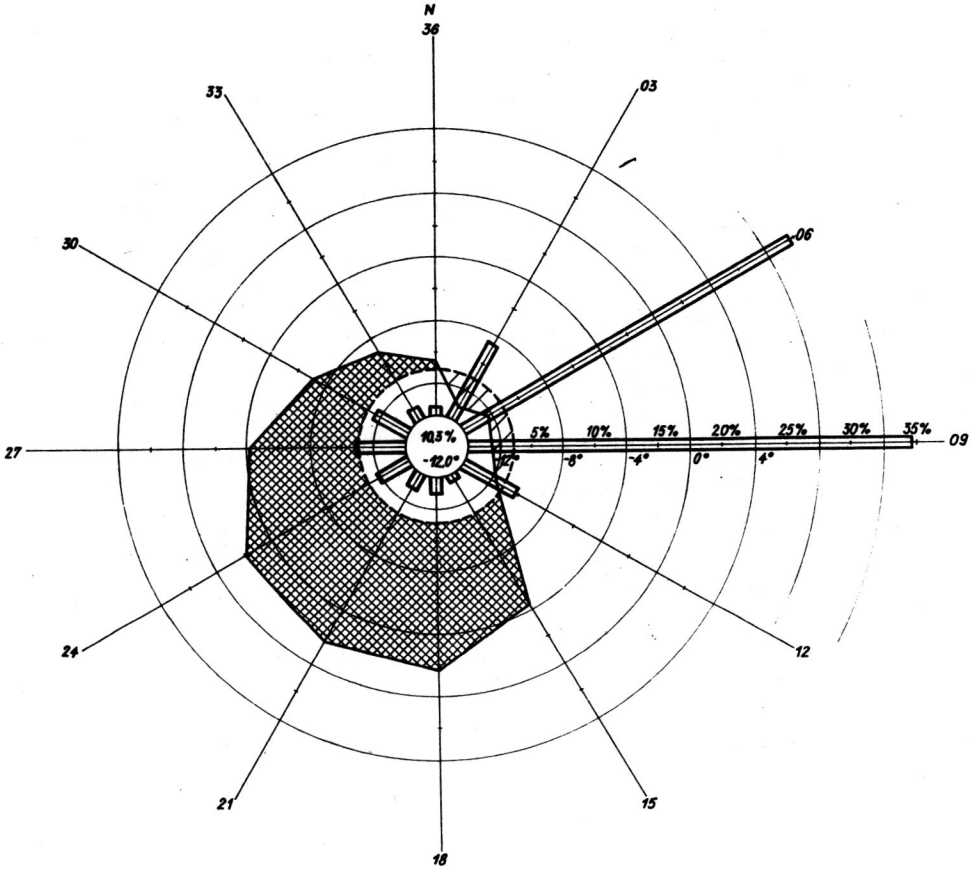

Fig. 3.

For explanations see: F

C

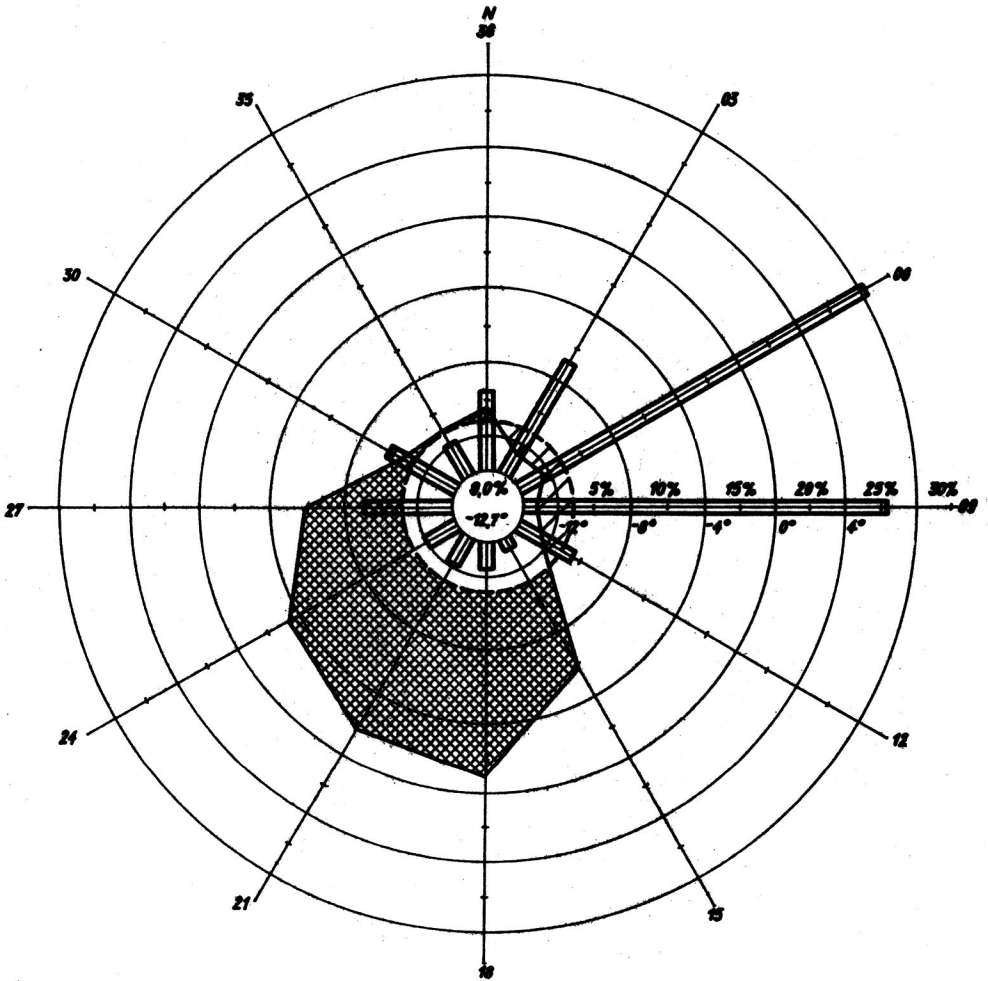

Fig. 3.

For explanations see: F

D

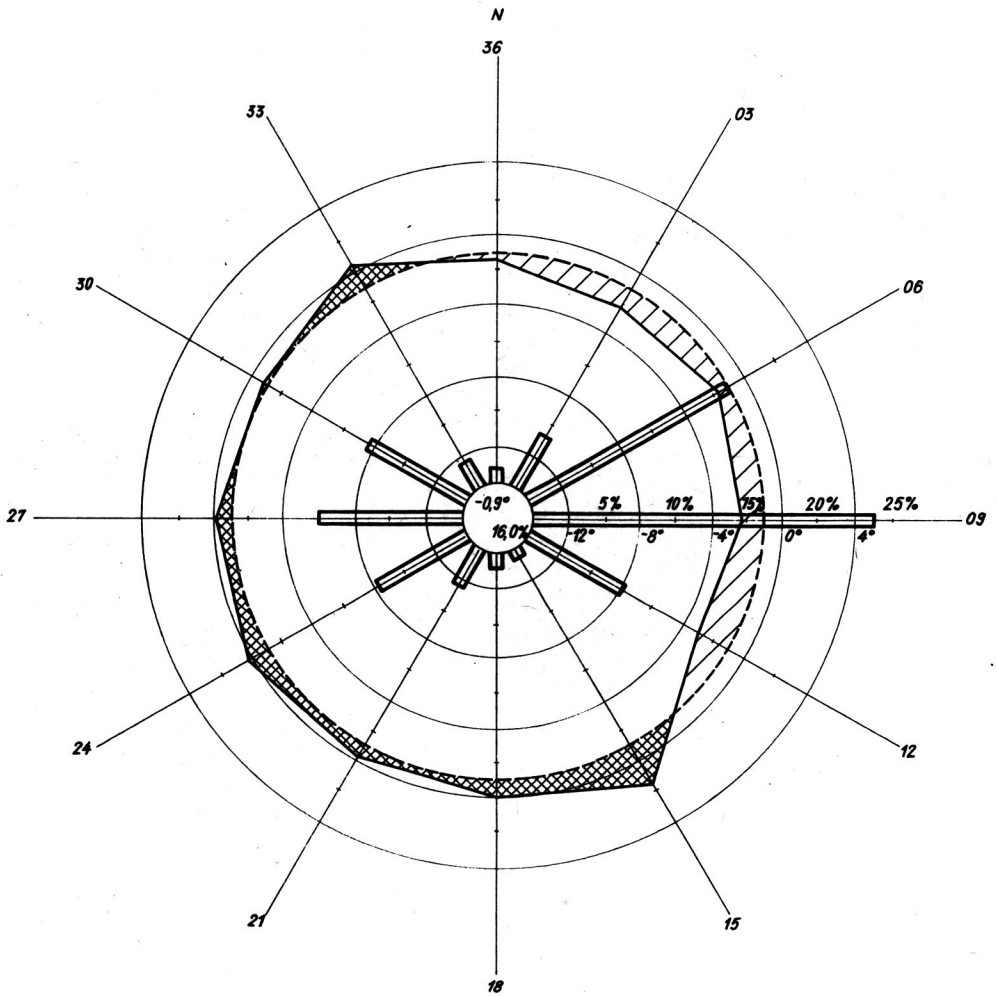

Fig. 3.

For explanations see: F

E

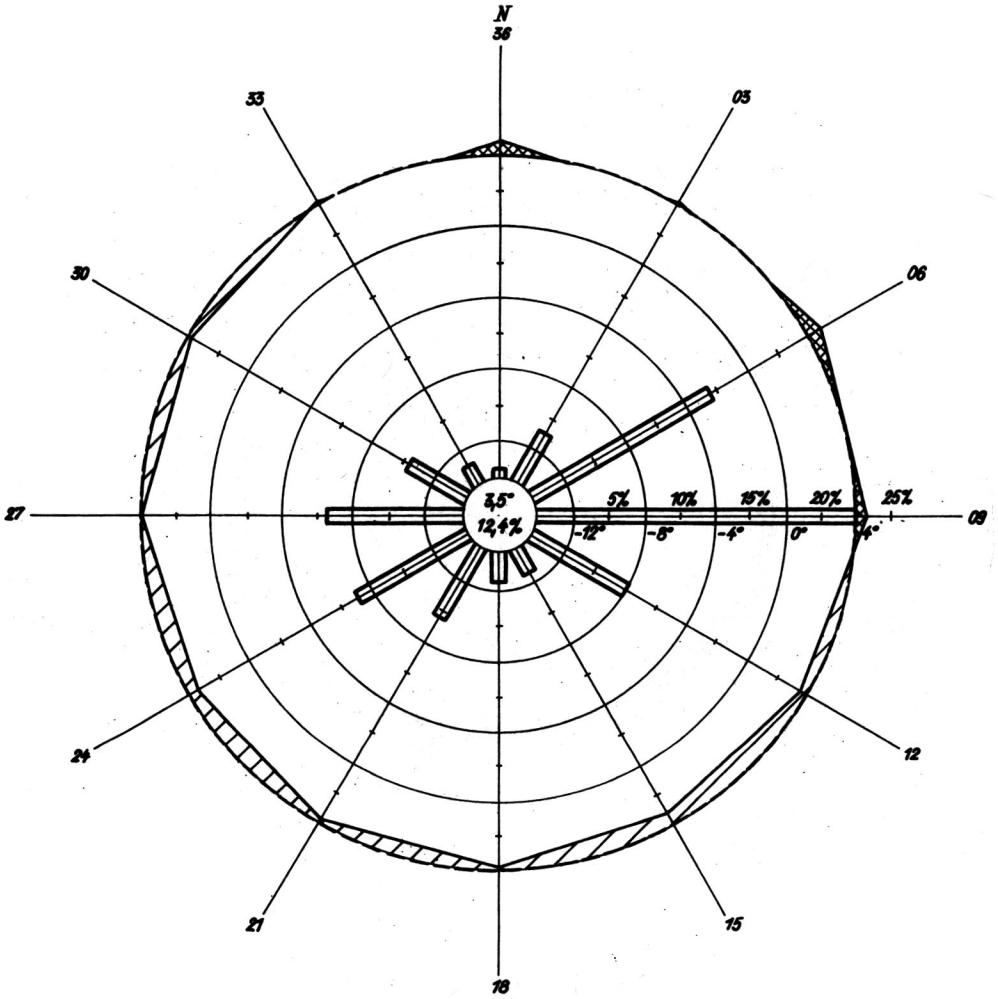

Fig. 3.

For explanations see: F

F

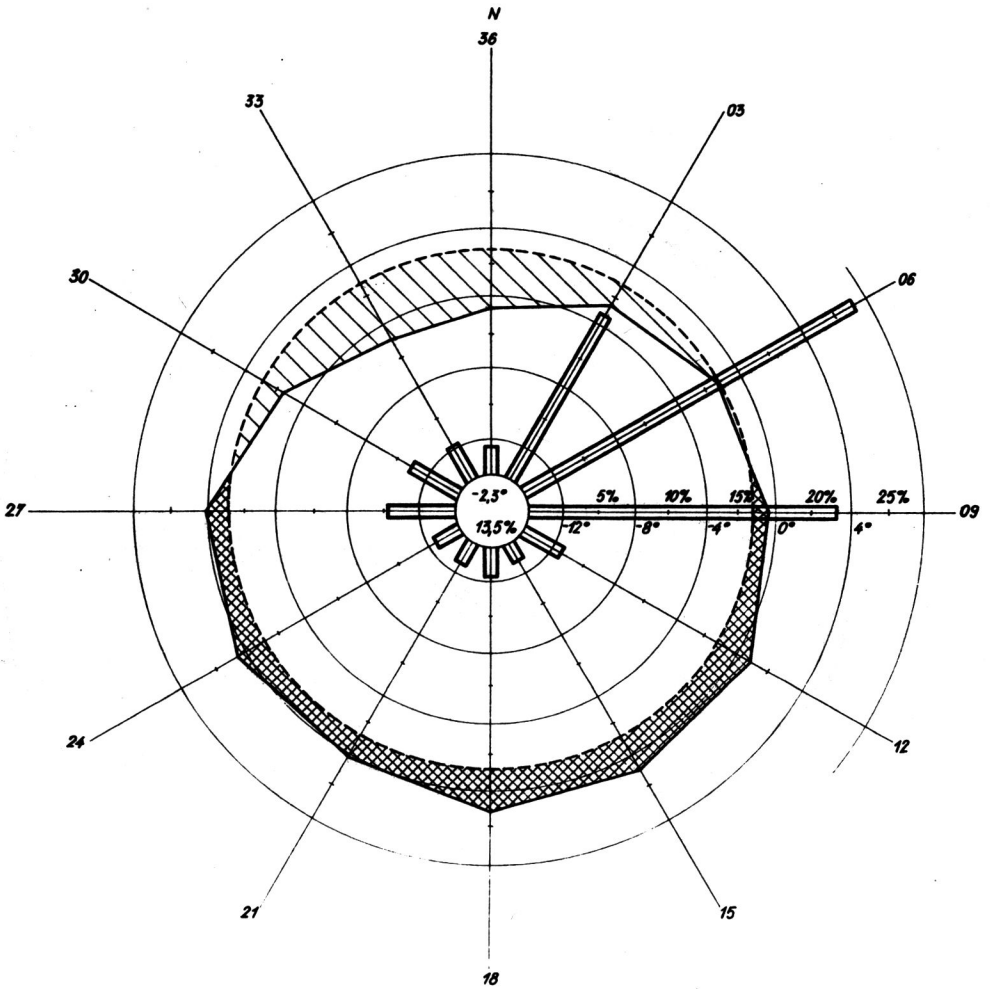

Fig. 3. Relation between air temperature and wind direction at Hornsund station. Data from July 1978 — July 1981 and September 1982 — July 1984. Numbers in circles indicates frequency (in %) of calms and their mean temperatures. Chequered area mean positive deviation from mean seasonal temperature, and hatched area — negative deviation from mean seasonal temperature. A — November-December, B — January-February, C — March-April, D — May-June, E — July-August, F — September-October.

Tabela 4

Deviations (in °C) of mean air temperatures at particular wind directions from mean seasonal temperatures. Observations from July 1957 — August 1958, July 1978 — July 1981, October 1982 — July 1984

Direction	Deviations					
	Jan — Feb	Mar — Apr	May — Jun	Jul — Aug	Sep — Oct	Nov — Dec
360° (N)	0,9	0,8	-0,2	0,6	-3,4	0,9
30°	-1,3	-2,0	-0,9	-0,1	-1,2	1,4
60°	-1,0	-1,0	-0,4	0,5	0,0	-1,3
90° (E)	-1,9	-1,2	-0,9	0,3	0,9	-2,2
120°	-1,1	-0,4	-1,7	-0,5	2,1	-0,4
150°	5,6	6,8	2,9	-0,8	2,1	0,0
180° (S)	10,5	9,6	1,3	-0,2	2,3	6,0
210°	9,6	9,5	1,0	-0,2	1,4	8,9
240°	8,0	9,2	1,5	-0,5	1,9	5,9
270° (W)	5,4	7,1	1,2	0,0	1,3	5,0
300°	0,8	4,1	0,5	-0,2	-1,5	3,4
330°	0,6	2,3	1,7	0,1	-3,7	1,7
Calm	-1,4	-0,8	0,4	-0,4	-1,1	-0,7

temperature of air from sector 300°—360° is close to the mean air temperature for this time but at the end of the winter, in March and April, winds from this sector bring warmer air (Fig. 3c).

Spring (May and June) has considerably lower deviations of air temperature at defined wind directions, from the seasonal mean equal -1.3°C . Positive deviations to 3°C are noted at air flows from southeast (150°), south (180°), west (270°) up to north-west (330°). Westerly directions are more frequent at this time than in winter. Negative deviations from the mean air temperature are noted at air flows from northeasterly, easterly and southeasterly sectors (360° to 120°), and vary from -0.2°C to 1.7°C (Fig. 3d).

Summer season (July and August) brings further increase in frequency of westerly winds and does not indicate any particularly prevailing direction as far as thermal features of air flow are concerned (Fig. 3e).

In autumn (September and October), a differentiation is again clear. "Cold" winds come from northerly directions (from 300° to 30°). The most frequent direction at this time (60°) is "thermally indifferent" that is mean air temperature from this direction is equal the mean air temperature of all directions. Winds from the broad sector from west (270°), south (180°) to east (90°) bring warmer air (Fig. 3f).

Final remarks

Presented picture of mean air temperature distribution dependent on wind directions and season of the year remains in close connection with

frequency of defined synoptic situations that bring western Arctic warmer air from southwesterly directions and cooler air from northerly and easterly directions. Such analysis is however beyond the topic and scope of this paper.

Accessible observation data enable to calculate only frequency of wind directions and mean air temperatures. They could not be used for calculations of other statistic characteristics as standard deviation, due to insufficient number of data at certain wind directions. In spite of several observation years, winds from the direction of 150° occurred just in a few cases only and from other directions only in several cases.

References

- Baranowski S. 1968. Termika tundry peryglacialnej południowo-zachodniego Spitsbergenu. — Acta Univ. Wrastisl., Studia Geogr., 10: 1—74.
- Petelski T. 1981. Przebieg pogody w Hornsundzie podczas wyprawy "Spitsbergen 1978/79". — Gazeta Obserwatora IMGW, 6 (390): 13—15.
- Steffensen E. L. 1982. The climate at Norwegian Arctic stations. — Klima, 5: 44 pp.
- Stepko W. and Rodzik J. (*in press*). Course of weather in Hornsund during the expedition "Spitsbergen 1982/83". — Annales UMCS, 30.

Received January 14, 1987

Revised and accepted August 29, 1987

Streszczenie

Na podstawie obserwacji z 7 całorocznych wypraw polarnych Polskiej Akademii Nauk do Hornsundu: 1957/58, 1978/79—1980/81 i 1982/83—1984/85, przedstawiono częstość występowania kierunków wiatru (tab. 1 i fig. 1) oraz prawdopodobieństwo wystąpienia określonych wartości temperatury powietrza (tabl. 2 i fig. 2). Obliczono też średnią temperaturę jaka przypadła na każdy kierunek wiatru. Obliczenia wykonano dla okresów dwumiesięcznych, które łatwo można pogrupować stosownie do termicznych pór roku w Hornsundzie, gdzie zima trwa 6 miesięcy a pozostałe sezony po około dwa miesiące.

W omawianych okresach średnia temperatura zimy (od listopada do kwietnia) wynosiła -11°C , wiosny i jesieni (odpowiednio: maj—czerwiec i wrzesień—październik) nieco poniżej -1°C , a temperatura miesięcy letnich, lipca i sierpnia, sięgała 4°C (tab. 3). Jednocześnie w ciągu całego roku bardzo dużą przewagę miały wiatry wschodnie i północno-wschodnie (90° i 60°) osiągając łącznie od około 40% do 65% przypadków (tab. 1 i fig. 3). Spośród pozostałych kierunków, około 10% częstości osiągały późną jesienią wiatry północno-wschodnie z dużą składową północną (30°) a latem głównie zachodnie i południowo-zachodnie (270° i 240°) a także południowo-wschodnie (120°).

Przy takim rozkładzie temperatur i kierunków wiatru rysuje się wyraźnie zróżnicowanie termiczne napływającego powietrza w zależności od kierunku jego napływu. Najbardziej jest to widoczne zimą. Występujące sporadycznie wiatry z sektora południowego i zachodniego (od 150° do 300°) przynoszą znaczne ocieplenia sięgające nawet 10°C (tab. 4, fig. 3).

Odchylenia dodatnie, lecz mniejsze przynoszą również wiatry północnozachodnie i północne. Kierunki wschodnie przynoszą temperatury o 2°C niższe niż średnie. Wiosną obraz ten nie ulega zasadniczym zmianom, jedynie wartości bezwzględne odchyłeń są mniejsze. Lato jest okresem, w którym żaden z kierunków wiatru nie jest termicznie uprzywilejowany, a jesienią tylko kierunki z sektora północnego (od 300° prze 360° do 30°) przynoszą powietrze chłodniejsze niż temperatura średnia.

Praca została wykonana w ramach tematu CPBP 03.03. B 13.