

DOI 10.24425/ae.2020.134633

A new method to reduce electromagnetic interference using signal modeling

MILAD DANESHVAR^{ORCID}, NASSER PARHIZGAR, HOMAYOON ORAZI

*Department of Electrical Engineering, Shiraz branch, Islamic Azad University
Shiraz, Iran*

e-mails: milad_daneshvar@yahoo.com, mehrad13921710@gmail.com, h_orazi@iust.ac.ir

(Received: 11.02.2020, revised: 08.07.2020)

Abstract: Controlling and reducing the radiation emitted by various systems helps the board designer improve systems' performance. One proposed way to achieve these goals is to use an algorithm to control the radiation applied to systems. According to the executive structure of the algorithm and considering the nature of the existing signals in several components, the separation of the signal components is on the agenda of the algorithm. In fact, the goal is to create an intuitive view of the multi-component signals around the systems that enter the systems from different angles and have a detrimental effect on their performance. Using signal processing methods, we will be able to break down the signal into different components and simulate each component separately. To prevent high computational repetitions and increase simulation time in signal component analysis, by reducing the components, we reduce the number of mesh cells in the software and, using linear approximation, determine the exact position of the radiation signal applied to systems and thus the best linear relationship. The signal entry path is used to apply the rules required for prediction design.

Key words: electromagnetic radiation, frequency response, interference, multi-component signals, parameter modeling, transmission lines

1. Introduction

One of the most obvious interference is that radiation has an adverse effect on systems and disrupts systems' performance. Many articles and books have been published in this field so far. Many researchers have professionally proposed various methods and criteria to reduce interference that has been achieved experimentally or theoretically. The idea of creating parametric modeling in reducing the order of transmission lines is not a new method. Recently proposed



© 2020. The Author(s). This is an open-access article distributed under the terms of the Creative Commons Attribution-NonCommercial-NoDerivatives License (CC BY-NC-ND 4.0, <https://creativecommons.org/licenses/by-nc-nd/4.0/>), which permits use, distribution, and reproduction in any medium, provided that the Article is properly cited, the use is non-commercial, and no modifications or adaptations are made.

methods have been developed to focus on the static functions of the subject, but the applied purpose is to analyze the parametric modeling of multi-component signals by improving the signal quality and reducing the order of transmission lines [1]. Creating any parametric model with the assumption that any electrical behavior of the elements in systems can be modeled by a variable dynamic system in the time domain, also has the ability to run for nonlinear systems. The proposed method for generating parametric modeling of multi-component signals has a linear dependence on each parameter and can reduce the linear differential equation by using a continuous transmission process. The approach used in line with linear reduction methods to reduce electromagnetic interference is confronted with the fact that the production of linear structural systems from the path of transformation is achievable, and in this transformation, it is easy to make the linearity effect by changing a variable from a time axis to frequency [2, 3].

The need to speed up the work has always been a challenge for printed circuit board (PCB) designers. The demand for high frequencies requires in-depth knowledge of the frequency constraints of circuits. In the past, the frequency of systems did not exceed a few megahertz, and the way of connecting and positioning elements and paths did not affect the circuit efficiency, but nowadays, with the increase in the frequency by a few gigahertz, design rules must be observed. Therefore, it is necessary to consider how to design the range and signal paths and the distance between the paths and layers and in the overall path of the signals with greater accuracy [4–6]. Therefore, it is necessary to pay more attention to the signal model. Signal paths are investigated and then compensated for the effects of the presence of high-frequency parameters to ensure the integrity of the signal. Signal integrity or SI is a set of measures of the quality of an electrical signal. However, digital signals are fundamentally analog in nature, and all signals are subject to effects such as noise, distortion, and loss. It is an important activity at all levels of electronics packaging and assembly, from internal connections of an integrated circuit (IC), through the package, the PCB, the backplane, and inter-system connections [6]. At high frequencies, there are a lot of problems that compromise the integrity of the signal. One of these problems is the reflection or the radiation process. When the signal energy is not transmitted completely, and in fact, part of the signal returns to the source, it will weaken the signal and reduce the signal quality, in which case signal integrity will be difficult. Reflection occurs if the impedance of the source terminals and the impedance of the load and impedance of the transfer path are not matching. Also, all the interconnection lines between the various elements of the circuit have resistive, self-inductive, and capacitive effects that cannot be ignored at high frequencies. It should also be noted that not only the frequency of signals is a determinant, but the rise and fall times of the signal are also decision criteria. In fact, the shorter the rise and fall times of the signal, the more damage is done [7]. By studying potential problems in signal paths and compensating for these effects as well as matching impedance in paths and observing the distance between paths, etc., signaling speed in circuits can be greatly improved, and the signal quality and power consumption can be improved. When modeling long-length conductors in an internal circuit of a system, the knowledge of how to distribute resistors and capacitors and, sometimes, a half-look at the effect of a self-contained circuit in a circuit is essential. However, the computation of parameters at some desired design of a PCB can lead to the creation of multiple situations of the existing conditions [8–10]. The rest of the paper

is organized as follows: section 2 proposed and described a parametric method. In addition, a new algorithm for a received signal in a system is investigated in section 3. In section 4, the results and analysis of the proposed method are evaluated, and section 5 contains conclusions.

2. Proposed parametric method

In this paper it is attempted to use the mean frequency of each component and taking into account the view of parameters resulting from modeling, equations of state are found in the following relations [10]:

$$E(s_1, s_2, \dots, s_\mu)x = Bu, \quad (1)$$

$$B = Cx. \quad (2)$$

In Equations (1) and (2), the parameters s_1 to s_μ are of the type of micron parameters, x represents the state of the system, and $E(s_1, s_2, \dots, s_\mu)$ is the subspace of the n order that represents a system matrix and u is the unit matrix. B is the matrix of system inputs, and C is the matrix of system outputs that can be rewritten using $E(s_1, s_2, \dots, s_\mu)$ and using the wide-ranging capability of the series [11, 12].

$$E(s_1, s_2, \dots, s_\mu) = E_0 + \sum_i s_i E_i + \sum_{h,k} s_h s_k E_{h,k} + \sum_{h,k,j} s_h s_k s_j E_{h,k,j} + \dots \quad (3)$$

One of the easiest methods available to generate a series of potentials that can be designed using the Taylor series is to rewrite Equation (4) as follows:

$$\begin{aligned}
 E(s_1, s_2, \dots, s_\mu) = & E(s_1^*, s_2^*, \dots, s_\mu^*) + \sum_i \frac{\Delta s_i}{s_i^*} \left[(s_1^*, s_2^*, \dots, s_\mu^*) \right] + \\
 & + \sum_{h,k} \frac{\Delta s_h}{s_h^*} \frac{\Delta s_k}{s_k^*} \left[s_h^* s_k^* \frac{\partial^2 E}{\partial s_k \partial s_h} (s_1^*, s_2^*, \dots, s_\mu^*) \right] + \dots \quad (4)
 \end{aligned}$$

In Equations (4)–(6) and (15), “*” on each signal is a conjugate sign between parameters that were used in the mentioned equations. A method based on timing consideration and signal integrity requirements is described in this paper. In the signal integrity, it checks the accuracy of the signals in the circuit. The signals in the circuit, which can be digital data or clock pulses or other items, are examined in terms of amplitude, mutation, interference, and timing. An iterative method of computation combines a numerical formulation of signal waveforms that are approximated by the multivariable Taylor series. These series are formulated as constraints on delays and shapes of waveforms at a PCB in a linear parametric model at each iteration which lead to data integrity problems due to delays that occur on the operation of the system. Taking into account the requirements of signal integrity in the circuit, it always avoids sudden surges and sub-mutations, and as a result, the impedance discontinuity is reduced, which leads to a reduction in the radiation emitted from the PCB. The discontinuities always occur in practical communication paths that lead to impedance discontinuity, unwanted signal transduction, and dramatic radiation emission. The linear model allows one to find new values of parameters consistent with signal integrity

requirements. On each step deviation from the required arrival signal waveform decreases as a result of changes made in parameters. The process converges very fast. In the field of operational execution, for example, from the creation of a direct ratio of numerical values to each parameter, the matrix method can be used as best as possible, and the operating variable is given according to the ratio $\frac{\Delta s_i}{s_l}$, which results from normalization, the actual parameters are displayed as follows:

$$\left[V \cdot E_0 V + \sum_i S_i V \cdot E_i V + \sum_{h,k} s_h s_k V \cdot E_{h,k} V + \sum_{h,k,j} s_h s_k s_j V \cdot E_{h,k,j} V + \dots \right] x =$$

$$= V \cdot Bu \Rightarrow y = CVx. \quad (5)$$

In Equation (5), the expression $V \in C^{(n \times q)}$, and the size of q are obtained from the reduced order matrices of the system. According to the calculation of the creation of the matrix V , it is very useful to reuse the power series for the functional matrix of the system and rewrite it [13] and x represents the state of the system.

$$\left[I \cdot E_0 V + \sum_i s_i (-E_0^{-1}) E_i + \sum_{h,k} s_h s_k (-E_0^{-1}) E_{h,k} + \right.$$

$$\left. + \sum_{h,k,j} s_h s_k s_j (-E_0^{-1}) E_{h,k,j} + \dots \right] x = E_0^{-1} Bu. \quad (6)$$

In this equation:

$$x - \left[I - \sum_i s_i (-E_0^{-1}) E_i + \sum_{h,k} s_h s_k (-E_0^{-1}) E_{h,k} + \right.$$

$$\left. + \sum_{h,k,j} s_h s_k s_j (-E_0^{-1}) E_{h,k,j} + \dots \right]^{-1} E_0^{-1} Bu = \sum_{m=0}^{\infty} \left[\sum_i s_i (-E_0^{-1}) E_i + \right.$$

$$\left. + \sum_{h,k} s_h s_k (-E_0^{-1}) E_{h,k} + \sum_{h,k,j} s_h s_k s_j (-E_0^{-1}) E_{h,k,j} + \dots \right]^m E_0^{-1} Bu. \quad (7)$$

The easiest way to create a context for reducing the order of the column V matrix is to define a set of new parameters called \tilde{s}_l :

$$\tilde{E}_l = \{E_i\}, \quad i = 1, 2, \dots, \mu, \quad (8)$$

$$\tilde{E}_l = \{E_{h,k}\}, \quad h = 1, 2, \dots, \mu, \quad k = 1, 2, \dots, \mu, \quad (9)$$

$$\tilde{E}_l = \{E_{h,k,j}\}, \quad h = 1, 2, \dots, \mu, \quad k = 1, 2, \dots, \mu, \quad j = 1, 2, \dots, \mu, \quad (10)$$

$$\tilde{s}_l = \{s_i\}, \quad i = 1, 2, \dots, \mu, \quad (11)$$

$$\tilde{s}_l = \{s_{h,k}\}, \quad h = 1, 2, \dots, \mu, \quad k = 1, 2, \dots, \mu, \quad (12)$$

$$\tilde{s}_l = s \{E_{h,k,j}\}, \quad h = 1, 2, \dots, \mu, \quad k = 1, 2, \dots, \mu, \quad j = 1, 2, \dots, \mu. \quad (13)$$

Like previous states, it can be rewritten for parametric models.

$$[\tilde{s}_1 \tilde{E}_1 + \tilde{s}_2 \tilde{E}_2 + \dots + \tilde{s}_p \tilde{E}_p - \tilde{A}] x = Bu \Rightarrow y = Cx. \quad (14)$$

By simpler modeling due to applying matrix methods, we can write:

$$[\tilde{s}_1 V \cdot \tilde{E}_1 V + \tilde{s}_2 V \cdot \tilde{E}_2 V + \dots + \tilde{s}_p V \cdot \tilde{E}_p V - V \cdot \tilde{A} V] \hat{x} = V \cdot Bu \Rightarrow y = CVx. \quad (15)$$

Concerning the matrix V , the equation can be represented as follows:

$$[I - (\tilde{s}_1 M_1 + \tilde{s}_2 M_2 + \dots + \tilde{s}_p M_p)] \hat{x} = B_M u \Rightarrow y = CVx, \quad (16)$$

which we define in Equation 5:

$$\begin{aligned} M_i &= \tilde{A}^{-1} \tilde{E}_i, \\ B_M &= -\tilde{A}^{-1} B, \end{aligned} \quad i = 1, 2, \dots, p. \quad (17)$$

Finally, with respect to the recent equations, the following relation can be reached:

$$\begin{aligned} x &= \left[I - (\tilde{s}_1 M_1 + \dots + \tilde{s}_p M_p) \right]^{-1} B_M u = \sum_{m=0}^{\infty} (\tilde{s}_1 M_1 + \dots + \tilde{s}_p M_p)^m B_M u = \\ &= \sum_{m=0}^{\infty} \sum_{k_2=0}^{m-(k_3+\dots+k_p)} \dots \sum_{k_p-1=0}^{m-k_p} \sum_{k_p=0}^m \left[F_{k_2, \dots, k_p}^m (M_1, M_2, \dots, M_p) B_M u \right] \\ &\quad \left[(s_1^{m-(k_2+\dots+k_p)} \tilde{s}_2^{k_2}, \dots, \tilde{s}_p^{k_p}) \right]. \end{aligned} \quad (18)$$

In fact, with the above method, we were able to access the parametric linearization of the system state matrix. By using the main parameters and taking into account the space between the conductors or the paths of the signal carrier, as well as how frequency interference occurs, and the details of the frequency response, one can understand the difference between the values simulated in the model with the reduction of the order and the original model, and this, of course, is very small and minor. In analog simulators, there are two main parts: a SPICE time-domain simulator and frequency domain simulator, using S linear or nonlinear harmonic parameters. Each of these known simulation areas has its own strengths and weaknesses that can be the best in the simulation conditions. The final goal of the mentioned formulas is electromagnetic reduction using reduction of the order in the transfer function.

3. A new algorithm for received signals in the system

Several methods can be used to detect input signals to the system. One of the methods used in the present study is to use a uniform analysis to differentiate signals based on the time of entry and

time interval between input signals to the system using correlation topics and also regression is the corresponding algorithm shown in Figure 1. The goal of correlation is to find out the intensity and nature of the linear relationship between independent and dependent variables. The nature of the positive or negative slope of the variables is relative to each other.

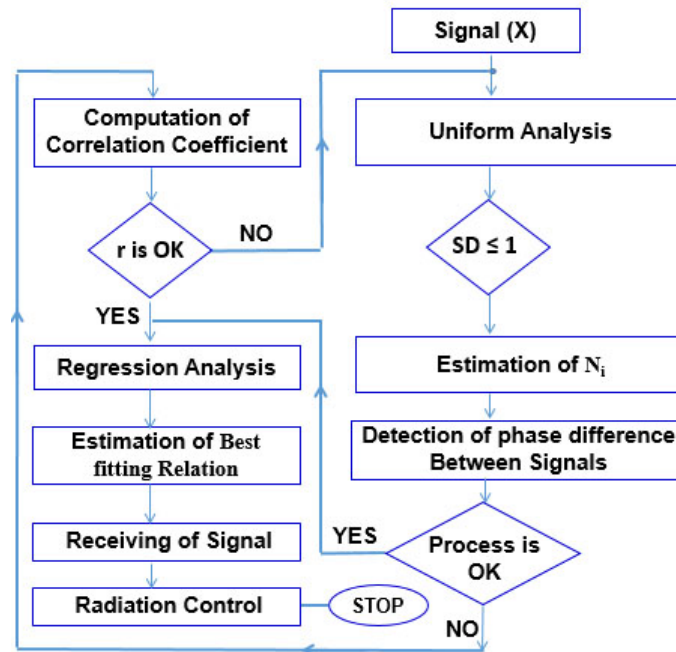

Fig. 1. Implementing the radiation control algorithm of system input signals

Some parameters are introduced for better understanding and the calculation of the standard deviation of a stopping criterion (SD) and the N_i function, which is defined as an ordered pair of T_i and C_i , is obtained from the following equation.

$$N_i = (T_i C_i), \quad (19)$$

$$SD = \sum_{i=1}^n \left(\frac{C_i}{T_i} \right). \quad (20)$$

In the above relations, C_i indicates the time of entering the signals and T_i is the time interval between the signals entered into the system.

3.1. The hypothesis of selective algorithm

Assumption 1: The N_i criterion is intermittent. Here the periodicity (T_i) is equal to the distance between two consecutive receivers of each criterion (N_i) or, in other words, the time interval between the arrival of signals and the assumed coordinates.

Assumption 2: All steps of the intermittent criterion (N_i), from the moment of sending by the radiation source to the moment of receiving by the subsystem, include the computational time of C_i or, in other words, the time of signals entering the subsystem.

Assumption 3: All criteria are independent.

Assumption 4: The criteria take precedence over each other, and this means that there is no signal overlap at the moment of entering the subsystem. The diagram in Figure 1 shows the relationship between the different components of the algorithm. The input signals to the subsystem after a uniform analysis for non-differentiation between the signals mentioned in hypothesis 4 are compared with the proposed stop criterion and if the criterion is realized, the estimation of signal entry angle and time interval between signals entering the subsystem is calculated. Accordingly, the phase difference between the signals is obtained, and if the measured phase difference is acceptable, regression analysis is performed to calculate the regression line, which is always the best way for the signal to enter the subsystem. The radiation received the received signals under the system. If any of the algorithm steps are not performed, repeat the uniform analysis on the signals again until the desired result is achieved. In the proposed stopping criterion (SD), the operator applies a separate deduction on the face and denominator at each desired time interval, and then the two resulting values are divided and the problem does not occur.

4. Results and discussion

Essentially, the most important challenge in the design of signal integrity is the choice of suitable values for the elements of the transmission line. These values, with the help of tuning in Advanced Design System (ADS) software and with high accuracy, are chosen with the proper matching on the input and output circuits, to achieve good returns. This tuning is quite purposeful and according to the existing relationships between the impedance characteristic of the input and output virtual transmission line, along with proper analyzes. One of the most important parameters in designing the signal integrity is the importance of input impedance matching and then output in the design of the matching network, the noise number and increase of the gain should always be considered. The simulation before the layout is required in the early stages of PCB design. At this stage, several topologies are evaluated and the selection of one such feature, such as space, the number of components and performance, is inevitable. In addition, the results of these simulators are used to adjust the important parameters for the transmission structure, such as the width of the path, the path distance, the maximum path length, and the component placement and selection of components and topologies that help to align the signal path properly. The analysis of the results is used to set the design rules, to simulate the physical specifications provided by the manufacturer (which may differ from factory specifications). As mentioned above, to check the integrity of the signal, input and output buffers are used, and each of these buffers uses the transistor manufacturer's file technology. In Figure 2, the circuit shown in the software is shown. For analysis, the input buffer is applied to a pulse, and this pulse must be observed at the output as shown in Figure 3.

The package designed to improve the simulation results should consider the management of the radiation level at the PCB, which will reduce the time and cost of implementing the design and

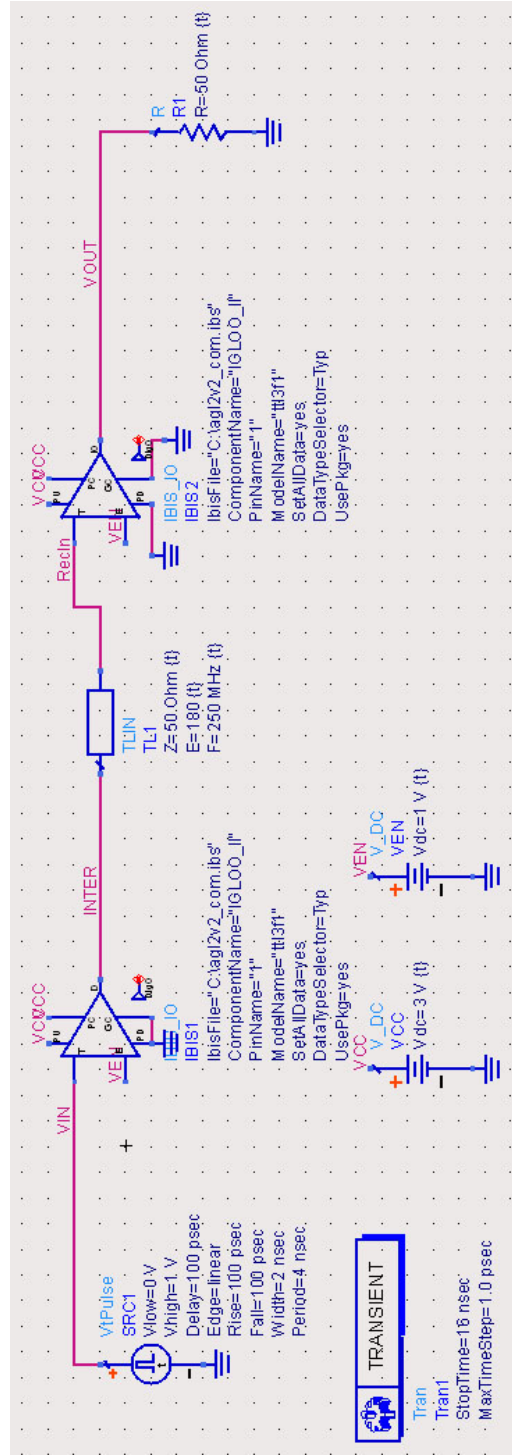

Fig. 2. The simulation of signal quality with ADS software

manufacturing process. In order to achieve this goal, the integrity (signal, power, heat and data) is of great importance. With the modeling and analysis of the transmission line parameters to reduce electromagnetic interference, good results can be obtained from the correct operation of the PCB. Due to the nature and location of the components and the complexity of the input signals, it also increases the reliability of components and the tolerance of electromagnetic interactions, to evaluate the performance of the subsystem under the influence of radiation, various simulations and results were recorded.

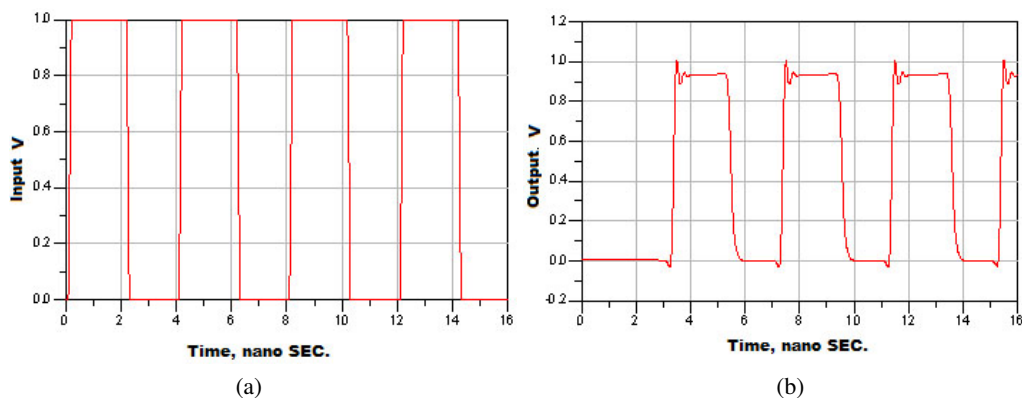

Fig. 3. View of the waveforms: input (a); output (b)

In analyzing signal integrity, we need to know the inputs and outputs of the IC. The integration of the signal resulting from the reversal losses gives the integration that is visible in the eye diagram. If the eye diagram is open it is better because the data is more reliable. When we solve the signal integrity problem, the eye closes [8]. In fact, there is a trade-off between the eye diagram width and signal integrity status. A communication path consists of a fully electrical connection that starts at the transmitter signal and ends at the receiver signal. Numerous articles have discussed the transmission line and its analysis methods, and in fact, one of the most common methods in reducing electromagnetic interference is to reduce the order of transmission lines. We are always looking for comprehensive and accessible solutions so that we can achieve the best performance to attain the goals of the present study with less time wasted. The eye diagram is a common method for assessing the quality of signals emitted in a communication pathway, taking into account three metric indicators: eye coverage, eye height, and jump. If the height increases and the jump decreases, we will see an acceptable eye chart. This diagram is created by a string of quasi-random bits.

The waveforms of input and output are shown. Also, this circuit was an analysis of the eye diagram, in which the schematic circuit is shown in Figure 4. The eye diagram is shown in Figure 5. The eye diagram is a statistical model and the more open its eyes; the better its signal integrity.

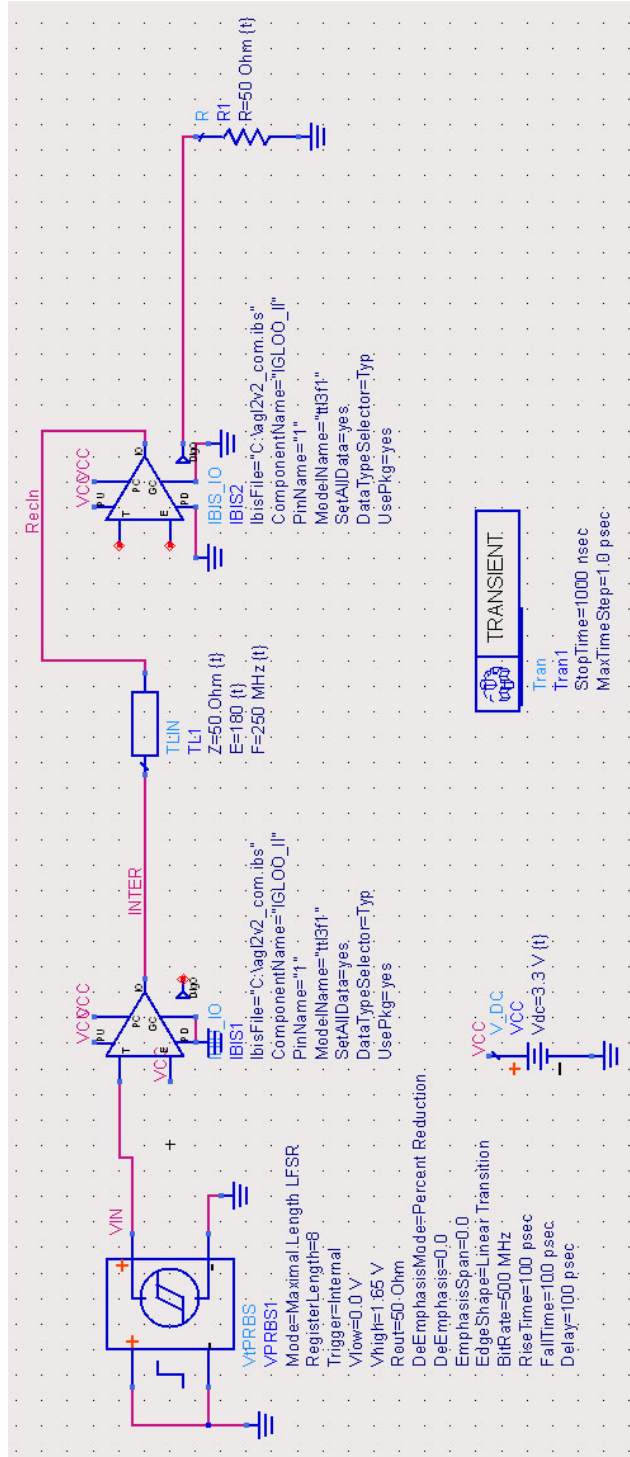

Fig. 4. The eye diagram analysis with ADS software

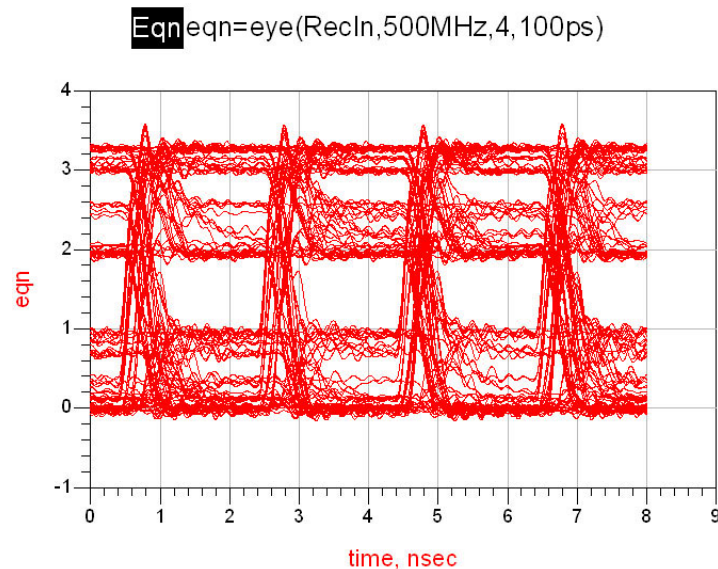

Fig. 5. The signal eye diagram

5. Conclusions

Given that in various industries, the issue of electromagnetic interference has always plagued electronic and telecommunication systems and imposed exorbitant costs on the systems, it is worthwhile working on these issues in a very special way, because it is not a device that is not subject to interference and if the design considerations are ignored, the consumer market and customers will be in danger of being exported over time. In this paper, we tried to give a different description in the context of looking at generating models related to parametric circuits for the analysis of in-system models. Therefore, the recent method has helped us to access the automated method in this regard, while this approach follows the expansion of the power series depending on the model's decreasing parameters. The impact of the applied methods, taking into account the multi-parameter model reduction methods, can be well utilized by considering the coupling of resistive and capacitive elements in the operational path of the latter view. Among other research fields, applying the reduced-order parameter and improving the quality of the signal in the capacitive effects of each chip can occur with the application of a decreasing order algorithm, which can significantly reduce the size and capacity of existing capacitors. Diagnosing the specialized radiation section of a subsystem is a multifaceted problem. In this study, due to a comprehensive algorithm in the field of providing services, it helps one to operate the system. According to the executive structure of the algorithm and considering the nature of the existing signals in several components, the separation of the signal components is on the agenda of the algorithm. In fact, the goal is to create an intuitive view of the multi-component signals around the systems that enter the systems from different angles and have a detrimental effect on their performance.

References

- [1] Jafari H.A., Abbasi Z., Azhari S.J., *An Offset-free High linear Low Power High Speed Four-Quadrant MTL Multiplier*, Emerging Science Journal, vol. 1, no. 3, pp. 129–134 (2017), DOI: 10.28991/ijse-01115.
- [2] Berdnikov V., Lokhin V., *Synthesis of Guaranteed Stability Regions of a Nonstationary Nonlinear System with a Fuzzy Controller*, Civil Engineering Journal, vol. 5, no. 1, pp. 107–116 (2019), DOI: 10.28991/cej-2019-03091229.
- [3] Omidi A., Karami R., Moradi H., *Design of the Low Noise Amplifier Circuit in Band L for Improve the Gain and Circuit Stability*, Emerging Science Journal, vol. 1, no. 4, pp. 192–200 (2018), DOI: 10.28991/ijse-01122.
- [4] Singh P., Joshi S.D., Patney R.K., Saha K., *Fourier decomposition method for nonlinear and non-stationary time series analysis*, Proceedings: Mathematical, Physical and Engineering Sciences, vol. 473, pp. 1–27 (2017), DOI: 10.1098/rspa.2016.0871.
- [5] Schuster C., *Ensuring Signal and Power Integrity for High-Speed Digital Systems*, IEEE International Conference on Consumer Electronics (ICCE), Berlin, Germany, pp. 205–210 (2016), DOI: 10.1109/ICCE-Berlin.2015.7391234.
- [6] Cats O., Jenelius E., *Planning for the Unexpected: The Value for Reserve Capacity for Public Transport Network Robustness*, Transportation Research Part A: Policy and Practice, vol. 81, pp. 47–61 (2015), DOI: 10.1016/j.tra.2015.02.013.
- [7] Lundstedt H., Persson T., Andersson V., *The extreme solar storm of May 1921: observations and a complex topological model*, Annales Geophysicae, vol. 33, pp. 109–116 (2015), DOI: 10.5194/angeo-33-109-2015.
- [8] ITU, *High-power electromagnetic immunity guide for telecommunication systems*, ITU-T, K.81 (2016).
- [9] Rasilainen K., Ilvonen J., Viikari V., *Antenna matching at harmonic frequencies to complex load impedance*, IEEE Antennas and Wireless Propagation Letters, vol. 14, pp. 535–538 (2014), DOI: 10.1109/LAWP.2014.2370760.
- [10] Radasky W., Bäckström M., *Brief Historical Review and Bibliography of Intentional Electromagnetic Interference (IEMI)*, XXXI-th URSI General Assembly and Scientific Symposium (URSI GASS), Beijing, China (2014), DOI: 10.1109/URSIGASS.2014.6929517.
- [11] Chen Q., Li L., Wang Y., *Amplitudes of mono-component signals and the generalized sampling functions*, Signal Processing, vol. 94, pp. 255–263 (2014), DOI: 10.1016/j.sigpro.2013.06.034.
- [12] Schuster C., Donadio R.R., *Modeling of Power Supply Noise Effects on High Speed Interconnects*, Workshop on Power and Signal Integrity Co-Design for High-Speed Circuits (WS7), IEEE Asia-Pacific EMC Symposium (APEMC), Melbourne, Australia, pp. 1–56 (2013), DOI: 10.1109/MEMC.2013.6623300.
- [13] Duan X., Donadio R.R., Brüns H.D., Schuster C., *Fast and Concurrent Simulations for SI, PI, and EMI Analysis of Multilayer Printed Circuit Boards*, Asia-Pacific Symposium on Electromagnetic Compatibility, Beijing, China, pp. 614–617 (2010), DOI: 10.1109/APEMC.2010.5475683.