

# Robotic Mobile Holder (For CAR Dashboards)

Srilatha Madhunala, Bhavya Kanneti, and Priya Anathula

**Abstract**—In the current smart tech world, there is an immense need of automating tasks and processes to avoid human intervention, save time and energy. Nowadays, mobile phones have become one of the essential things for human beings either to call someone, connect to the internet, while driving people need mobile phones to receive or make a call, use google maps to know the routes and many more. Normally in cars, mobile holders are placed on the dashboard to hold the mobile and the orientation of the phone needs to be changed according to the driver's convenience manually, but the driver may distract from driving while trying to access mobile phone which may lead to accidents. To solve this problem, an auto adjustable mobile holder is designed in such a way that it rotates according to the movement of the driver and also it can even alert the driver when he feels drowsiness. Image Processing is used to detect the movement of the driver which is then processed using LabVIEW software and NI myRIO hardware. NI Vision development module is used to perform face recognition and servo motors are used to rotate the holder in the required position. Simulation results show that the proposed system has achieved maximum accuracy in detecting faces, drowsiness and finding the position coordinates.

**Keywords**—LabVIEW; image processing; Servo Motor; NI myRIO; face detection; phone holder

## I. INTRODUCTION

AS science and technology are growing tremendously day by day, the use of automated devices and robots has become very popular and diversified. Automation is a technique of making things or a process happen automatically which can be used to respond to a particular signal or data and also make devices act autonomously to perform some action. In current technology, many things around us are automated like a kettle, which turns off when the temperature reaches a particular threshold, an automatic sanitizer dispenser which dispenses sanitizer automatically when a person's hands were sensed and the most popular automated system in current technology are smart homes and cities.

Mobile robots also come under automated systems and different types of mobile robots differ based on the functionality that they offer. Some examples of mobile robots are humanoid robots which mimic human behavior, pre-programmed robots work in controlled environments to perform simple tasks to avoid human intervention., autonomous robots can be operated in an open environment to operate tasks without human intervention which uses sensors to capture data and facilitate respective functionality, teleoperated robots are controlled by humans that use wireless networks, and augmented robots are used to replace human potential and also to enhance performance. Using the autonomous robot technology, the proposed system is designed to work as a mobile holder as

shown in fig.1 which autonomously changes its orientation according to the detection of the person's height. DC motors and servo drivers are used to support low-power versions as well as vehicle drive systems which can be controlled by using a PID controller. The speed can be controlled by a variety of controllers, and the speed and position can be controlled by different positioners. NI LabVIEW is used as the programming environment which is a graphical programming environment where users can deploy and test real-world applications.



Fig. 1. Mobile Holder

## II. RELATED WORK

According to authors in [1], FPGA was used to control speed and servo motor function within the Quartus II 10.0 programming environment. To control and position the servo motor accurately, the system employs a PID controller. Using FPGA, they have optimized the system design making it easier, safer, and more reliable to operate but, algorithms and hardware optimization are difficult to achieve. So, there is a need to improve the control program. In order to provide a solution to the mobility problem for paralyzed people, authors in [2] developed an eye-controlled wheelchair. The eye images are sent to MATLAB script for processing after acquiring them using a camera that is attached to the wheelchair. This system mainly involves two stages, which are face detection and controlling the wheelchair by sending control signals but, high-end image processing techniques need to be applied in real-time.

Using the Haar Cascade Classifier of OpenCV, Thin Swe presented a technique for detecting faces by applying the Apache Hadoop concept to solve the computational time burden in detecting faces from large-scale images [3]. Compared to other techniques, proposed method will be able to execute

Authors are with Department of ECE, Vardhaman College of Engineering, India (e-mail: [ma\\_srilatha2@yahoo.co.in](mailto:ma_srilatha2@yahoo.co.in), [bhavyakanneti23@gmail.com](mailto:bhavyakanneti23@gmail.com), [bhavyakanneti23@gmail.com](mailto:bhavyakanneti23@gmail.com)).



faster. However, they have not yet included a method for classifying different facial expressions. Researchers describe algorithms in [4] for detecting short periods of artificially induced nystagmus. In detecting these short periods, an accuracy of 98.77% is achieved. A conventional technique for measuring nystagmus during calorie testing has also been collected, analyzed, and compared with vestibular-induced nystagmus. But the system is not robust to sudden impulses of noise, couldn't normalize the CRP, and has no accurate SPV estimation. Authors in [5] presented the efficiency of LabVIEW programming in controlling servo systems through PI, PID control, and sliding mode control. They have used both LabVIEW programming and Math script RT. The first step of implementation is a simulation with the controllers and Math script modules and NI myRIO module is used to control the servo system.

Using fuzzy-based PID controller technology, authors [6] proposed a hybrid controller. Their performance has been compared between fuzzy-based PID controllers and individual PID controllers. It is found that no matter how well the PID controller controls the parameters, the fuzzy controller provides easier computing while controlling the parameters. According to their findings, fuzzy PID controllers provide better performance than conventional PID controllers. An object sorting technique based on machine vision was presented in [7] which aids in the resolution of sorting failures caused by imperfect edges and a variety of colours. To capture the image, a camera is used, after which it is calibrated.

The image is processed using HSI colour space transformation, Gaussian filter for image filtering, Otsu's approach for image binarization, and Canny edge detection methods. The LabVIEW edge-based geometric matching technique is applied for template matching once the image has been pre-processed. If the acquired image matches the template image, an electrical signal will be transmitted to the robotic arm for object sorting once the vision assistant has analyzed the image. Under different conditions, the system has generated scores ranging from 800 to 1000.

The author [8] developed a sliding mode control (SMC) solution based on internal model control (IMC) to achieve high-performance motion control of servo motors subject to uncertainty and disturbances. In certain tracking situations, the IMC-based controller is not only straightforward and intuitive but also takes into account the efficacy of the SMC scheme in ensuring the reliability of the servo system. By using the Lyapunov theory, the stability of the servo system has been investigated.

There is a continuous terminal sliding mode control technique for servo motor systems presented in [9] is a novel full-order sliding mode surface which has the property of bilimit homogeneity. In other words, depending on the initial state, the sliding motion is finite-time stable. By using this sliding mode control algorithm, it is ensured that the system states will arrive at the sliding surface in a limited amount of time. By ensuring reliability and continuity, the suggested controller is more appropriate for mechanical systems that employ servos.

The authors [10] discuss the features and modules of OpenCV, as well as how OpenCV works in Python. The authors of this research emphasized the importance of OpenCV in applications such as face detection and recognition. A number of OpenCV applications were discussed such as face detection, facial

recognition, object recognition, and facial expression recognition. The sliding mode control approach for controlling the real-time position of a servo system was introduced in [11]. In this research, SMC methods were evaluated on a DC servo system and their performance was compared to that of a DC motor. A servo system implements three dedicated SMC controllers in real-time. Based on the SMC approach, the DC servo system has demonstrated its efficiency.

Author [12] demonstrates the usage of LabVIEW and Arduino to measure pressure, voltage, current, and volumetric flow in real-time of a centrifugal pump discharge using a data acquisition system. Authors claims that LabVIEW's graphical interface allowed to operate the system in individual, series, and parallel modes. The data are collected immediately from a text file, which eliminates the need for human labour.

Authors [13] developed a real-time system to track the sun position using Arduino UNO and LabVIEW. It continuously measures the voltage, light intensity of the solar panel, and current parameters. A voltage divider is used to measure voltage, ACS712 is used to measure current, and LDR is used to capture the maximum amount of light. The acquired data are processed in Arduino and sent to LabVIEW, which is a GUI. According to the maximum light source location, the solar panel is rotated using a stepper motor. This can be done either manually or automatically based on the location of the maximum light source.

LabVIEW is used to control the position of DC motors using a functional application presented in [14]. An encoder attached to the motor shaft provides feedback position signals to the PID controller using a closed-loop real-time control system. PID controllers can precisely control the position of DC motors. Through the Arduino board, the control signal was sent from the LabVIEW program to the real-time DC motor. Based on PID controller parameters, the system has been tested for disturbance rejection and at varied positions of the tracking signal. According to the findings, the developed controller accomplished the intended position with acceptable performance characteristics.

Based on the Simulink MATLAB and Arduino hardware implementation, authors [15] proposed a control system for tracking DC motors using an integral state feedback system. This article compares the PID controller results with those of its implementation. With an integral state feedback controller, setpoints and poles may change, but the controller still achieves the desired setpoint regardless. An encoder sensor is used to implement the controller which will oscillate in order to approach the setpoint based on the outcome. PID controllers are slower to rise and settle compared to integral state feedback controllers.

In [16] a method is outlined in which face detection is performed directly on the complete feature maps generated from a complex constructed convolutional neural network, which uses discriminative complete features. Several studies have demonstrated that DCFs can be scale-invariant, resulting in high speed and high-performance face detection. The proposed method differs from traditional methods of face recognition in that it does not require the extraction of multi-scale features from a pyramid image, so its accuracy for face detection can be greatly increased. In several popular face detection datasets, DCFs-based face detection has shown promising results.

Authors [17] mention that a single RGB camera can be used to classify human activities in real-time and that this method may also be applied to mobile robots. Open Pose and 3D-baseline, two open-source tools, were combined to extract skeletal joints from RGB photos, and convolutional neural networks were used to classify the activities. The final step of the process was to install a mobile robot platform with an NVIDIA JETSON XAVIER integrated board to monitor a person. An average of 15 frames per second (FPS) was achieved on the embedded board system, and 70 percent accuracy was achieved on the NTU-RGBD training dataset.

Through a series of controlled tests, the authors [18] built an automobile robotics with the feature of picture identification. myRIO-1900 is the main controller for the mobile robot. It also employs Tetrax and Matrix components in conjunction with an RC motor to serve as an arm in order to solve the competition problem, as well as trapezoidal acceleration and PID algorithms for more precise control. It uses NI LabVIEW Vision Assistant to perform picture identification processing to assist the mobile robot in completing the task.

Authors [19] proposed a cost-effective method to determine attendance patterns for students using a face detection and recognition. Since many facial characteristics such as lips, noses, and iris are distinct, it requires a good computational analysis to recognize the features. Using LabVIEW software, a simple and user-friendly GUI was created to present an automated class attendance system. By increasing lecture time and monitoring class attendance, this system will assure error-free attendance and improve the teaching-learning process.

Authors [20] describes an approach for using image analysis to automatically identify, segment, and classify specific cells, especially cancer cells. Using this method, the number of defective cells can be counted, and their location can be determined. LABVIEW provides practical applications for the image processing system since it can interface with other equipment within the system and control it in an automated fashion. In addition to increasing the accuracy and speed of the inspection as well as the faulty cell counting procedure, this technique can be employed in large-scale cell examinations. Table 1 shows the survey of existing systems.

Ref	Objective	Technology Used	Advantages	Shortcomings
[3]	Face detection	OpenCV, Webcam	Faster execution time compared to traditional approaches	Failed to classify different facial expressions
[7]	Object Sorting	LabVIEW, UniMAP, Walta Robot, Logitech C980E webcam	An accurate template matching score is achieved	The use of 3D machine vision failed to improve accuracy.
[10]	Face Detection and Recognition	OpenCV, Webcam	Different applications of OpenCV are explained	-
[11]	Position control of servo system	Slider Mode Control Method, Rotatory Servo System, Servo control unit, Loads	High performance in real-time motor controlling	Unable to eliminate vibrations and errors
[17]	Human Action Recognition	Open pose and 3D-baseline, Convolutional Neural Networks, RGB Camera, Motor Driver, Mobile robot	A low-cost RGB camera is used, 70% accuracy was achieved	Multi-person action tracking is not implemented
[18]	Mobile Robot based on the vision	LabVIEW, Mobile Robot, NI myRIO	Building vision-based control applications is easier with the LabVIEW platform	If the settings are not correct, then it will wrongly judge the appearance of image.
[19]	Class Attendance System	LabVIEW, Camera	An automated class attendance system reduces proxy attendance	During blackouts, the system doesn't support since there is no lighting
[20]	Classification of cancer cells	Image processing and LabVIEW	In order to monitor medical treatment, cancer cells can be detected and counted	Accuracy and speed need to be taken care while applying to large-scale

TABLE I  
SURVEY OF EXISTING WORK

Ref	Objective	Technology Used	Advantages	Shortcomings
[1]	Controlling and Positioning of a Servo motor	FPGA within Quartus II.0 programming environment, Computer, a Driver circuit, Servo motor controller	Using FPGA resulted in optimized system design	Difficulties in optimizing hardware and algorithm
[2]	Controlling a wheelchair by eye movements	MATLAB, Arduino, digital camera, DC motor, Ultrasonic sensor	Contact with the skin of the patient is not necessary	Implementing image processing in real-time is critical. Image processing at the highest level is needed to resolve this issue.

### III. SOFTWARE PLATFORM

#### A. LabVIEW Software

NI LabVIEW is used as the programming environment which is a graphical user interface, where users can deploy and test real-world applications. In LabVIEW programming, interface elements are represented as nodes, and structures are represented as loops. LabVIEW has a wide range of built-in functions and procedures. It can interface with many measurement and control devices irrespective of manufacturers. NI also has its own hardware devices like myRIO shown in fig.2 and myDAQ which are used to control and measure the DC servo system.

LabVIEW programs are called Virtual Instruments. In a nutshell, LabVIEW programs are referred to as Vis. Featuring powerful data acquisition, analysis, displaying, storing, and troubleshooting tools, LabVIEW helps to achieve the goals. It has two windows, one is the front panel and the other is a block diagram.



Fig. 2. NI myRIO

A front panel window is the VI's user interface that provides access to the control palette, which is a group of controls and indicators used to design the user interface and block diagram has elements such as terminals, sub-VIs, functions, constants, structures, and wires are used to illustrate graphical representations of the functions being handled by the front panel as shown in fig.3.

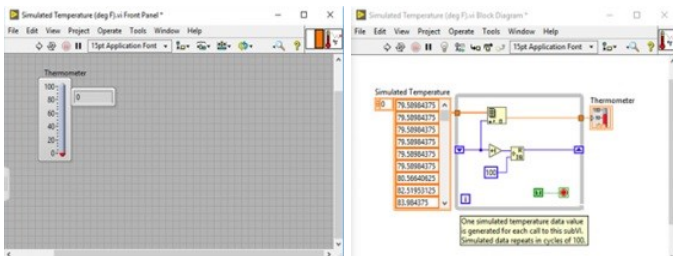

Fig. 3. Front panel and Block diagram

### B. NI Vision Development Kit

Vision Development Module provides various built-in functions or algorithms to develop and deploy machine vision-based applications. It is a software bundle provided by National Instruments which is used to develop machine vision-based applications and deploy applications to windows or NI Real-Time hardware. Fig. 4 shows NI vision acquisition function provided by vision development kit. The NI Vision Acquisition Software (VAS) allows user to acquire, display, and save images from a wide range of industry-standard camera interfaces, such as GigE Vision, USB3, and Camera Link. Additionally, this software allows to manage digital input/output on NI vision hardware. With the built-in functions and examples, it is easy and quick to create applications using LabVIEW or C/C++.

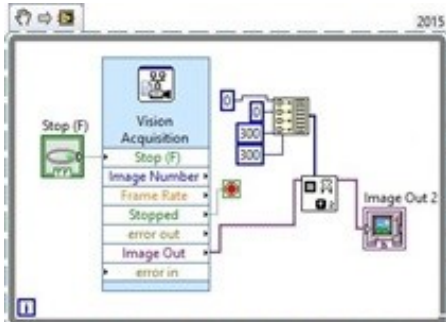

Fig. 4. Vision Assistant Function

## IV. BLOCK DIAGRAM

Fig 5 shows the block diagram of the proposed system. NI myRIO will control the devices by taking inputs, process it and passed to the output devices.

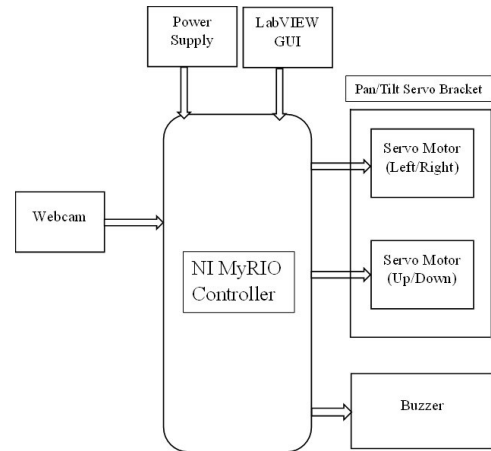

Fig. 5. Block Diagram of the Proposed System

### A. Servo Motor

Servo motors contain output shafts. A coded symbol can be provided to the servo to position the shaft at a specific angle. As long as the entry line contains the coded sign, the servo maintains the shaft's angular position. If the coded sign changes, shaft's rotation also changes. It is used to move the elevators and rudders of radio-controlled airplanes. Robots, puppets, and remote-control cars use them, too. Robotics relies heavily on servos. The motors shown in fig.6 are tiny and packed with a lot of power. They have built-in circuitry that controls their speed.



Fig. 6. Servo Motor

### B. NI Vision Development Kit

National Instruments' myRIO is an evaluation board which is used for real-time embedded applications. Using its integrated FPGA and microprocessor, it is used to develop applications. LabVIEW is necessary to run it. It is used for to design learning controls, studying mechatronics, and developing imaginative capstone projects through an embedded, WiFi-enabled solution. myRIO helps engineers learn PID theory by using hands-on applications.

### C. Power Supply

DC voltage is transformed from the AC voltage, typically 230Vrms, by a transformer, which also transforms it to the desired DC level. An initial C-L-C filter produces a DC voltage from a full-wave rectified voltage supplied by a bridge rectifier. It usually produces a relatively stable DC voltage with some ripple or variation in AC voltage. The dc input is used to provide

an output voltage that has much less ripple voltage and stays constant irrespective of the changes in the input voltage or in the load connected to the output voltage. Through a voltage divider circuit regulated DC supply can be obtained. Fig. 7 represents the circuit diagram for unregulated power supply.

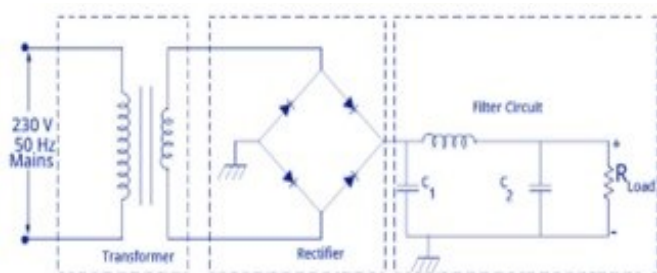

Fig. 7. Power Supply

#### D. Webcam

A webcam shown in fig.8 is a camcorder that sends or broadcasts an image or video via a network connection, such as the Internet, in real-time. Small cameras which sit on a desk, connect to a user's screen, or incorporated into the hardware are known as webcams. Webcams could be utilized throughout a video live chat between two or more persons, with live video and audio chats. Users can utilize webcam software to record or stream video over the Internet. Because video broadcasting over the Internet consumes a lot of bandwidth, compressed formats are commonly used and since larger resolutions would be lowered during transmission, a webcam's maximum resolution is likewise lower than that of the most handheld video camera. Webcams are less expensive than most video cameras due to their lesser resolution, yet the impact is sufficient for video chat conversations.



Fig. 8. Webcam

#### E. Pan/Tilt Servo bracket

This anti-vibration camera gimbal is made up of a Servo bracket PT pan/tilt camera platform shown in fig. 9 is a 2-Axis FPV and an SG90 micro servo. Most 912g tiny servos are compatible with it. It is simple to put a camera or other tiny components on the servo using this holder. On each axis, the servo bracket gives 180 degrees of freedom. Its specifications are:

- 37 mm x 33 mm x 3 mm / 1.5" x 1.3" x 0.1" base
- 30mm x 26mm / 1.2" x 1" Mounting Hole Distances
- 67mm / 2.6 inches (zero tilt) standing height"
- 38mm x 36mm / 1.5" x 1.4" top platform
- 37g in weight



Fig. 9. Pan/Tilt Servo bracket

#### F. Buzzer

Audio signals can be converted into sound signals by the buzzer, a sounding device and typically uses DC power. Electronic products such as alarm clocks, computers, printers, and other electronic products use it as a sound device. Piezoelectric buzzers and electromagnetic buzzers are the two main types. The electromagnetic buzzer can work at a voltage range of 1.5-24 V, and the piezoelectric buzzer can work at a voltage range of 3V-220V. A buzzer as shown in fig. 10 can be used to emit a variety of sounds depending on the design and use such as music, sirens, buzzers, alarms, and electric bells.



Fig. 10. Buzzer

### V. METHODOLOGY

The proposed system is divided into three parts: face detection, servo motor control and drowsiness detection. For face detection, morphology method is used to identify the image and its coordinates and edge detection method is used for drowsiness detection.

#### A. Face detection and Servo motor control

In the face detection part, Image processing is applied with the help of NI Vision Development module which includes Colour plane extraction, morphology, circle detection, lookup and pattern matching. The position coordinates obtained in face detection are sent to the servo control system which controls the servo's position as shown in fig. 11.

##### 1) Morphology

By using advanced morphological operations, gaps in particles are filled, particles that rub against the image's border are removed, unwanted tiny particles and large particles are removed, particles touching each other are separated, and the convex hull of particles is located, as well as facilitating quantitative analysis, these modifications are used to observe region geometry, identify simple forms, and identify particles. In the proposed design, morphology is applied on the acquired image to remove background objects and small objects. In this step minimum radius of the circle is set to 50 and maximum radius is set to 100 to detect large circles which indicates the presence of a person seated in the driver seat.

## 2) Circle Detection

Calculates the radius, surface area, and perimeter of overlapping circular particles and classifies them accordingly. Even when several circular particles overlap, it finds the radius and center of the circular particles starting from a binary image. This VI is also capable of tracking the circles in the destination image. By creating and using a Danielsson distance map, the radius of each object is calculated.

## 3) Pattern Matching

Learning and matching are the two stages of the pattern matching process. The method pulls gray values and/or edge gradients information from the stored templates during the learning step. The algorithm organizes and stores the data in such a way that it can be searched more quickly in the inspection image. The information gathered at this stage is saved as part of the stored templates in NI Vision. During the matching stage, the pattern matching method extracts gray values from the inspection image and/or edge gradients. In the inspection image, the algorithm finds matches by looking for locations that have the highest cross-correlation. A template is selected to choose match pattern and then an ROI is drawn around the face to store the gray values of the face. Correlation value pyramid algorithm is selected to match the template with real-world acquired image with a match score of 800 for an accurate result.

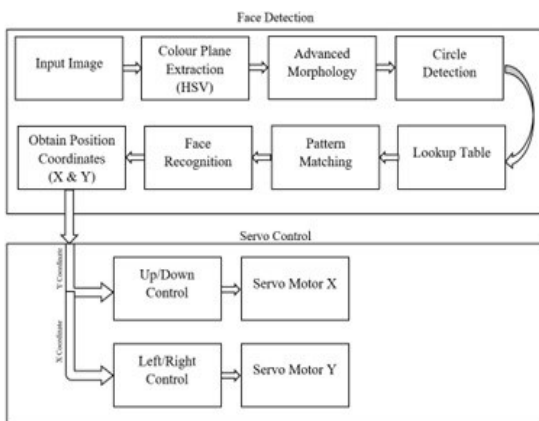

Fig. 11. Flow of Execution of Face detection and Servo Motor control

## 4) Pulse Width Modulation

Signals of variable width are transformed into pulses by pulse width modulation (PWM), which represents their amplitude. An output switching transistor is more active when a signal has a high amplitude and when the signal amplitude is low, the signal is off more of the time. Because PWM circuits are digital (always on or off), they can be made more cheaper than analog circuits. PWM is frequently used in remotely operated vehicle (ROV) applications to control the motor speed and/or illumination of lights. NI myRIO low level VIs are used to apply pulse input to the servo motor.

## B. Drowsiness Detection

Fig 12 represents the flow of drowsiness detection. Input images acquired using Vision Acquisition are sent to vision assistant to identify the eye edges of the driver using the edge detection method. When the grayscale values of neighbouring pixels in an image shift dramatically, an edge occurs. Asymmetrical 1D profiles of pixel values along a search zone are used by NI Vision to locate edges. A line, a circle or ellipse,

a rectangle or polygon, or a freehand region can be used to define the limits of a 1D search zone. The software utilizes the pixel values along the line to assess if there have been any major intensity variations as the profile progresses. Changes in intensity can have a variety of features that can be used to identify if they are edges. A line with two edges is drawn between the open eye lids of the template image of a person. By applying this algorithm, the system will continuously search for the two edges on the acquired image. Whenever the driver feels drowsy, automatically the driver's eyelids tend to close. The drowsiness of the driver can be detected by the proposed system and immediately alerts the driver by giving a loud buzzer sound.

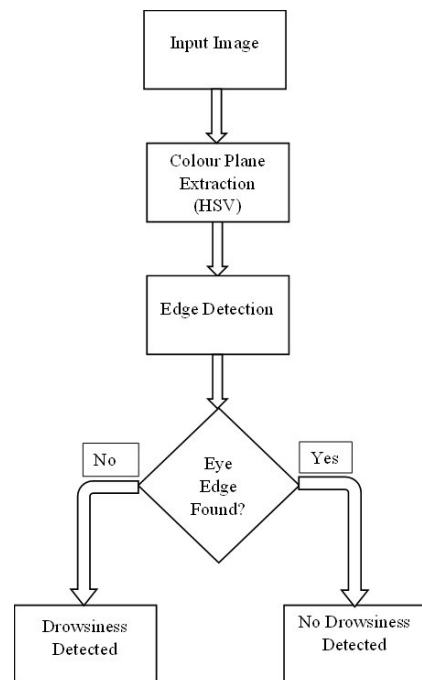

Fig. 12. Flow chart of Drowsiness Detection

## VI. RESULTS AND DISCUSSION

The proposed system is divided into three parts: face detection, servo motor control and drowsiness detection. National Instruments provides a vision development module that is used for face detection.

### A. Face detection and Servo motor control

The first step of face detection is acquiring input video. This is done using vision acquisition in continuous acquisition mode as shown in fig. 13. NI myRIO is connected to a USB camera for video acquisition. The output video is sent to the vision assistant to process and identify the image.

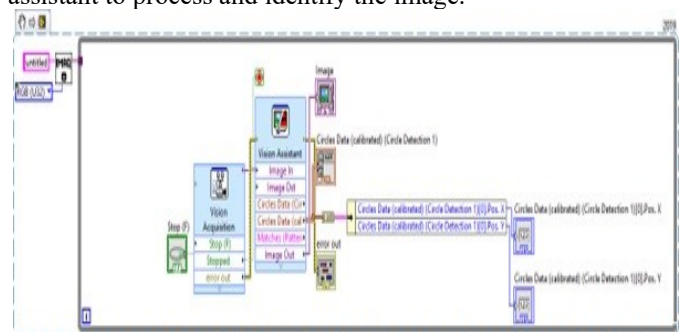

Fig. 13. Process of Face detection

For the acquired image, HSV color planes need to be extracted. To achieve this, a color plane extraction method is applied and HSV(Intensity) is selected as the output image type as shown in fig. 14. Any unwanted backgrounds are then eliminated by setting a threshold as shown in fig. 15. The images are then filled with advanced methods of morphology to fill the holes in the images and remove small objects. The morphology technique is applied more number times to remove any other disturbances and improve accuracy as shown in fig. 16.

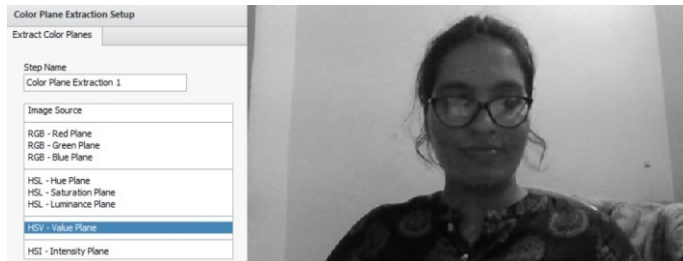

Fig. 14. Color Plane Extraction

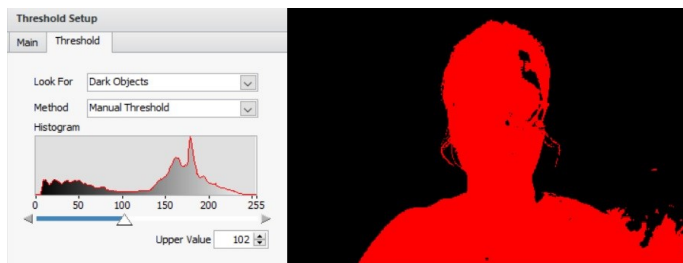

Fig. 15. Removing unwanted Pixels

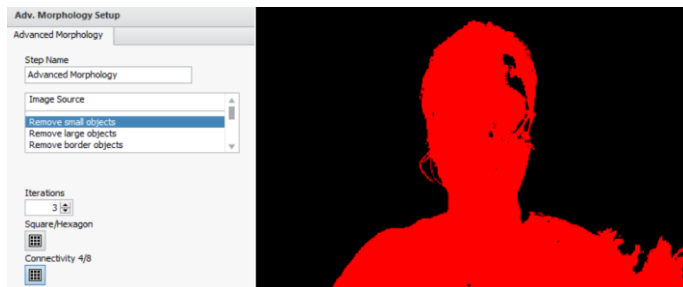

Fig. 16. Removal of Small objects

Then, circular edges are detected using the Circle detection method. This method will list out all the circles that were detected in the acquired image and the X, Y position values are sent to the output as shown in fig. 17. Binary images are converted further using a lookup procedure as shown in fig. 18. Pattern matching is applied to the output to match the trained template. These X, Y position coordinates are sent to the servo system for obtaining servo motor rotations. Servo motors receive input signals from PWM signals. Based on the circle data obtained from vision development module, servo motor need to rotate left/ right and top/down directions based on the threshold.

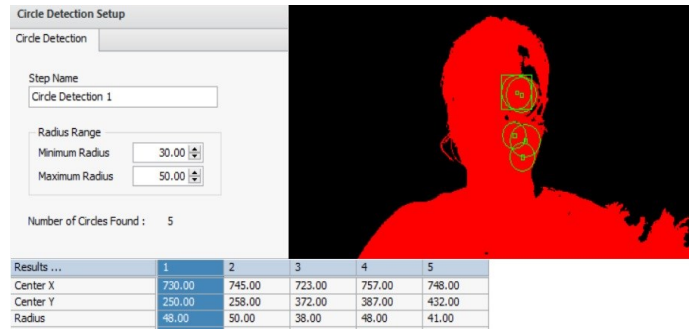

Fig. 17. Detecting Circular Objects

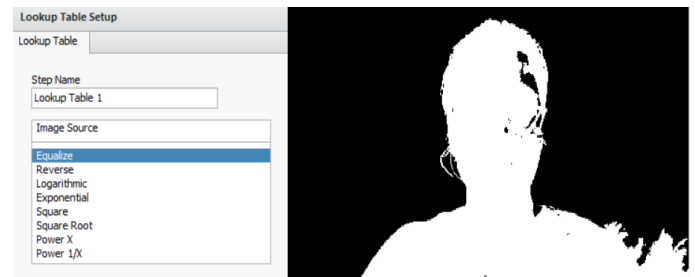

Fig. 18. Converting Image to Binary

**Case 1: Rotation in left or right**

If the circle data X coordinates are processed by changing the angle value, the position of the servo motor shaft will change. A case structure is used to determine angle values based on the obtained position values and if it is true, servo motor will rotate in left direction else rotate in right direction with a frequency of 50Hz as shown in fig. 19 and respective hardware set up for rotating left and right is shown in fig. 20 (a) and (b).

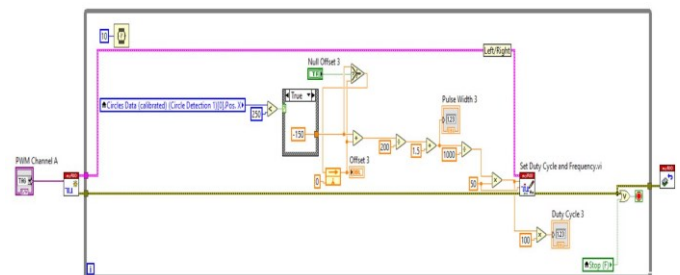

Fig. 19. Block diagram for Servo motor Left/Right rotation



Fig. 20 (a). Rotation of Servo motor in Left direction



Fig. 20 (b). Rotation of Servo motor in Right direction

**Case 2: Rotation in Top or Bottom**

If the circle data Y coordinates are processed by changing the angle value, the position of the servo motor shaft will change. A case structure is used to determine angle values based on the obtained position values and if it is true, servo motor will rotate in top direction else rotate in bottom direction with a frequency of 50Hz as shown in fig. 21 and respective hardware set up for rotating top and bottom is shown in fig. 22 (a) and (b). Table II shows different rotations. Fig. 23 shows the user interface to observe the X and Y coordinates, PWM values and image.

S. No	Angle	Rotation
1	-150	Left
2	+130	Right
3	-20	Bottom
4	-130	Top

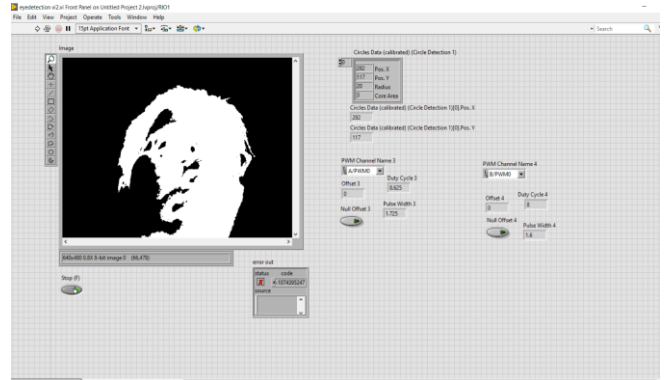

Fig. 23. Face detection and Servo Motor Control Front panel

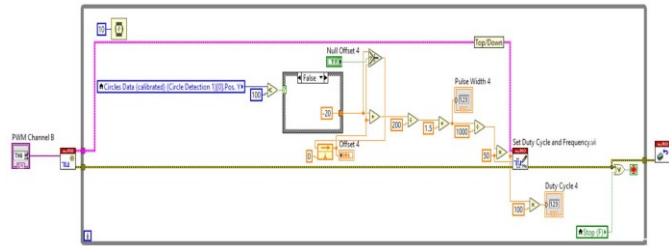

Fig. 21. Block diagram for Servo motor Top/Down rotation



Fig. 22 (a). Rotation of Servo motor in Top direction



Fig. 22 (b). Rotation of Servo motor in Bottom direction

*B. Drowsiness detection*

Fig. 24 represents the block diagram implementation of drowsiness detection. NI Vision Acquisition is used to acquire continuous images of the driver and then the images are sent to the Vision assistant module to detect the eye edges as shown in fig. 25. If eye edges are not found in the acquired image for a particular amount of time, then the proposed system will detect the drowsiness of the driver as shown in fig. 26 and the system will alert the driver with a buzzer sound, otherwise drowsiness is not detected as shown in fig. 27. By adding this functionality, the driver is able to prevent accidents before they occur.

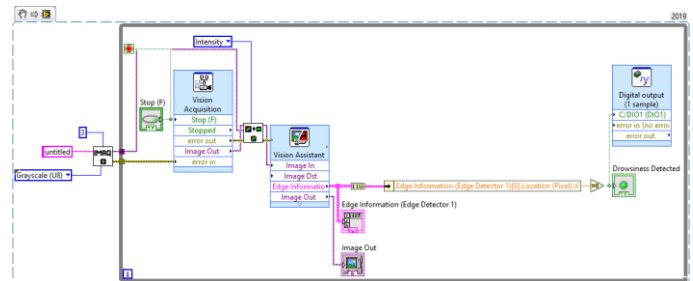

Fig. 24. Drowsiness detection Block diagram

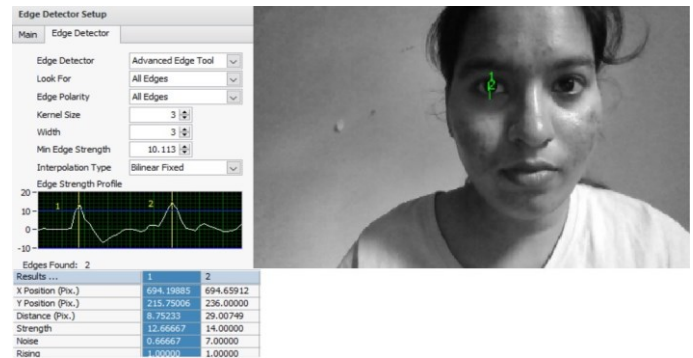

Fig. 25. Vision Assistant module for detecting Edges



Fig. 28 shows the proposed system which consists of NI myRIO, Servo motors, power adapter, Pan/Tilt Servo bracket, buzzer and a webcam.



Fig. 27. Drowsiness not detected

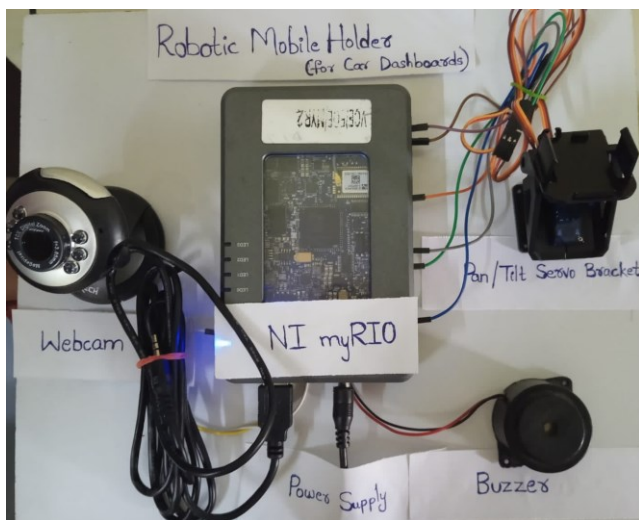

Fig. 28. Snapshot of the Proposed system

#### CONCLUSION AND FUTURE SCOPE

The proposed project is a mobile holder for car dashboards which is designed to prevent driver distraction from driving. The mobile holder is designed in such a way that it can auto adjust the height and position based on the height and eye movement of the driver. An algorithm for face detection is built using a pattern-matching algorithm within the NI Vision development kit and NI LabVIEW. The application is built using IMAQ functions for detecting the driver's face. The position of the driver obtained during detection is sent to the myRIO servo motor through local variables which rotate the servo motor in the desired direction. The system has achieved accurate results in tracking the driver's position in different lighting conditions. Also, driver drowsiness can be detected effectively by using edge detection algorithms.

As the driver needs to adjust the side mirrors according to his height to view the vehicles coming sideways on the roads for taking turns or parking. In future, the proposed design can be extended to apply to car side mirrors, which can be an add-on automation to the future automobiles.

#### REFERENCES

- [1] Ajel, Ahmed R., Huda M. Abdul Abbas, and Mohannad Jabbar Mnati, "Position and speed optimization of servo motor control through FPGA," *International Journal of Electrical & Computer Engineering*, vol. 11, no. 1, pp. 319-327, 2021, <https://doi.org/10.11591/ijece.v11i1.pp319-327>
- [2] Rani, Mrs Shilpi, Shubham Chitransh, Priyam Tyagi, and Prashant Varshney, "Eye Controlled Wheelchair," *International Journal of Scientific Research & Engineering Trends*, vol. 6, no. 3, pp. 1821-1823, 2020.
- [3] Swe, Thin Thin, "Detection of Faces from Images Using Haar Cascade Classifier," *Iconic Research and Engineering Journals*, vol. 3, no. 12, pp. 174-178, 2020.
- [4] Newman, Jacob L, John S. Phillips, Stephen J. Cox, John FitzGerald, and Andrew Bath, "Automatic nystagmus detection and quantification in long-term continuous eye-movement data," *Computers in biology and medicine*, vol. 114, pp. 103448, 2019. <https://doi.org/10.1016/j.combiomed.2019.103448>
- [5] Kiss, János Máté, Péter Tamás Szemes, and Petra Aradi, "Sliding mode control of a servo system in LabVIEW: Comparing different control methods," *International Review of Applied Sciences and Engineering*, vol. 12, no. 2, pp. 201-210, 2021, 10.1556/1848.2021.00250. <https://doi.org/10.1556/1848.2021.00250>
- [6] Somwanshi Devendra, Mahesh Bundeale, Gaurav Kumar, and Gajal Parashar, "Comparison of fuzzy-PID and PID controller for speed control of DC motor using LabVIEW," *Procedia Computer Science*, vol. 152, pp. 252-260, 2019. <https://doi.org/10.1016/j.procs.2019.05.019>
- [7] Tan, K. S., M. N. Ayob, H. B. Hassrizal, A. H. Ismail, MS Muhamad Azmi, M. S. M. Hashim, S. M. Othman, A. B. Shahrman, and Y. H. Low, "Integrating Vision System to a Pick and Place Cartesian Robot," *Journal of Physics: Conference Series*, vol. 2107, no. 1, 012037, IOP Publishing, 2021. <https://doi.org/10.1088/1742-6596/2107/1/012037>
- [8] Li, Ping, and Guoli Zhu, "Robust internal model control of servo motor based on sliding mode control approach," *ISA transactions*, vol. 93, no. 5, pp. 199-208, 2019, doi: 10.1016/j.isatra.2019.03.021.
- [9] Hou, Huazhou, Xinghuo Yu, Long Xu, Kamal Rsetam, and Zhenwei Cao, "Finite-time continuous terminal sliding mode control of servo motor systems," *IEEE Transactions on Industrial Electronics*, vol. 67, no. 7, pp. 5647-5656, 2019, <https://doi.org/10.1109/TIE.2019.2931517>
- [10] Hasan, Ramadan TH, and Amira Bibo Sallow, "Face Detection and Recognition Using OpenCV," *Journal of Soft Computing and Data Mining*, vol. 2, no. 1, pp. 86-97, 2021, <https://doi.org/10.30880/jscdm.2021.02.02.008>
- [11] Durdu, Akif, and Emre Hasan Dursun, "Sliding mode control for position tracking of servo system with a variable loaded DC motor," *Elektronika ir Elektrotechnika*, vol. 25, no. 4, pp. 8-16, 2019, <https://doi.org/10.5755/j01.eie.25.4.23964>
- [12] Quintero, D. A., H. Claro, F. Regino, and J. A. Gómez., "Development of a data acquisition system using LabVIEW and Arduino microcontroller for a centrifugal pump test bench connected in series and parallel," *Journal of Physics: Conference Series*, vol. 1257, no. 1, 012002. IOP Publishing, Jan 2019, <https://doi.org/10.1088/1742-6596/1257/1/012002>
- [13] Preethi, G., D. Lavanya, V. Sreesureya, and S. Boopathimanikandan, "Real time monitoring and controlling of solar panel using labview," *International Journal of Scientific and Technology Research*, vol. 8, no. 8, pp. 1747-1752, Feb 2019.
- [14] Khalifa, Mustafa, AL Hussein Amhedb, and Mohammed Al Sharqawi, "Position Control of Real Time DC Motor Using LabVIEW," *Journal of Robotics and Control (JRC)*, vol. 2, no. 5, pp. 342-348, 2021, <https://doi.org/10.18196/jrc.25104>
- [15] Ma'arif, Alfian, and Naufal Rahmat Setiawan, "Control of DC Motor Using Integral State Feedback and Comparison with PID: Simulation and Arduino Implementation," *Journal of Robotics and Control (JRC)*, vol. 2, no. 5, pp. 456-461, 2021, <https://doi.org/10.18196/jrc.25122>
- [16] Guo, Guanjun, Hanzi Wang, Yan Yan, Jin Zheng, and Bo Li, "A fast face detection method via convolutional neural network," *Neurocomputing*, vol. 395, pp. 128-137, 2020, <https://doi.org/10.48550/arXiv.1803.10103>
- [17] Lee, Junwoo, and Bummo Ahn, "Real-time human action recognition with a low-cost RGB camera and mobile robot platform," *Sensors*, vol. 20, no. 10, 2886, 2020, <https://doi.org/10.3390/s20102886>
- [18] Yang, Bo-Jun, Kuo-Hsien Hsia, Kuo-Lan Su, and Evgeni Magid, "Application of the myRIO Based Mobile Robot Using Vision System," In *Proceedings of International Conference on Artificial Life and Robotics*, Jan 2020, pp. 147-150, <https://doi.org/10.5954/ICAROB.2020.OS18-7>

- [19] Karthikeyan, R., G. Nalinashini, R. Chithrakkannan, K. Mohanraj, and B. Uma Maheswari, "Implementation of GUI for class attendance using face detection and recognition system," *International Journal of Innovative Technology and Exploring Engineering*, vol. 9, no. 1, pp. 2993-2996, Nov 2019, <https://doi.org/10.35940/ijitee.A9122.119119>
- [20] Zadeh, H.G, Janianpour, S. and Haddadnia, J, "Recognition and classification of the cancer cells by using image processing and labview," *International Journal of Computer Theory and Engineering*, vol. 5, no. 1, pp.104-107, 2013, <https://doi.org/10.7763/IJCTE.2013.V5.656>