

# A paradigm for building fire safety

Jadwiga FANGRAT 

Building Research Institute, Warszawa, Poland

**Abstract.** The aim of this study is to describe the fire safety paradigm using the concept of T. Kuhn, its components, and its role and significance for the further development of construction science, particularly the fire safety of buildings. The components of the fire safety paradigm form a complex structure (system) that is presented graphically to illustrate the interconnections and interactions between them. This structure is built by analogy with a three-dimensional coordinate system using linguistic quantities. Currently, it is not yet possible to assign a sequence of numbers representing the coordinates of a point in the space of this system. The three axes of this system determine the major groups of paradigm elements: – fire safety; – components; – activities and inputs. For each group, the components were distinguished and then briefly described and characterized, emphasizing their mutual connections and importance for the fire safety of buildings. Some significant gaps in the systemic approach to fire safety in the EU were discussed and illustrated by the example of the Grenfell Tower fire in London. The paradigm described is universal, and its universality is based on the possession of certain common attributes characteristic of the fire safety environment and their interpretation, as well as on the manner in which fire safety entities implement them. A paradigm shift will result in the introduction of a fire toxicity criterion for the assessment of construction products, which, for unknown reasons, has so far only been implemented in relation to cables. The second necessary amendment is the addition of a requirement for the spread of fires on building facades.

**Keywords:** paradigm; building; fire safety engineering; material database; sustainability.

## 1. INTRODUCTION

Thomas Kuhn, in his work published in 1962 [1], introduced the concept of the paradigm, which in recent decades has been part of the intellectual canon of the modern age, as it has been widely used in the various sciences, including technical sciences. The new paradigm in the metrology of concrete surface morphology [2] was probably the first contribution of this type in civil engineering. The contemporary paradigm of international security [3] was an inspiration for the area of fire safety. Moreover, it is worth mentioning the article [4] confirming suitability of “Kuhn’s concept of paradigm shifts as a tool for examining changes in research fields such as social science research methodology”. Based on these achievements, the idea was born to define the paradigm of fire safety in buildings, which has not yet been described. However, work [5], describing the gaps in fire safety engineering and research, can already be treated as a paradigm in this area.

The aim of this study is to describe the fire safety paradigm, its components, and its role and significance for further development of construction science, particularly the fire safety of buildings. This issue was considered in the background of the European system of basic requirements for buildings, in particular, basic requirement No. 2 “Fire safety” [6], of the European Sustainable Development Strategy and the European Green Deal climate policy [7], which implies the achievement of such goals in the construction industry as:

- 1) increasing the energy efficiency of buildings,
- 2) reduction of environmental burdens caused by construction,
- 3) ensuring that the functional requirements of buildings are met and ensuring the comfort of their users,
- 4) optimization of the costs of the full life cycle of construction products and structures.

These goals, in turn, determine changes in the approach to fire safety issues in buildings, primarily because of the following reasons:

- reducing the use of natural resources (e.g. natural aggregates and water);
- increasing the thickness of insulation and tightness of the building envelope, as well as increasing the share of complex products and systems (multi-material, multi-layer, including combustible ones) resulting from the need to meet the growing requirements of energy efficiency;
- an increase in the use of waste materials (recycling), which are usually characterized by an increased content of organic parts, that is, combustibles;
- the need to control the risk of fire (the level of fire safety assurance), which is not always adequate for the results of tests of materials and components of individual construction products as well as structural and non-structural elements of buildings;
- the negative impact of fires on the natural environment, primarily through the release of CO<sub>2</sub> and many other toxic and irritating compounds into the atmosphere, as well as contamination of water resources.

In this context, the scientific and engineering needs for implementation of the idea of sustainable development in the construction industry were indicated as a challenge for the decades to come [8].

\*e-mail: j.fangrat@itb.pl

Manuscript submitted 2024-04-26, revised 2024-10-25, initially accepted for publication 2024-10-27, published in March 2025.

The fire safety of buildings is aptly described in the second of the seven so-called basic requirements to be met by buildings and their location, listed in the EU Directive 89/106/EEC, and later replaced by the Construction Product Regulation [6]. This is expressed in the following specific requirements:

“The construction works must be designed and built in such a way that in the event of an outbreak of fire:

- (a) the load-bearing capacity of the construction can be assumed for a specific period;
- (b) the generation and spread of fire and smoke within construction are limited;
- (c) the spread of fire to neighbouring construction works is limited;
- (d) occupants can leave construction or be rescued by other means;
- (e) the safety of rescue teams is taken into consideration.”

## 2. THE CONCEPT OF PARADIGM FOR BUILDING FIRE SAFETY

The author of *The Structure of Scientific Revolutions* [1] argues that a fundamental change in professional and scientific achievements caused by an unusual situation (crisis) leads to a scientific revolution, which he describes by introducing the concept of a paradigm. However, he did not provide an unambiguous definition, leaving room for numerous analyses and interpretations that continue to this day.

The discussion on the problems of the paradigm is closely related to scientific work, regardless of the research discipline. It was assumed for further considerations that a paradigm can be identified with a scientific theory or a set approved by representatives of science at a given time and place. The scientific revolution, as interpreted by Kuhn, refers to an anomaly (deformation) that arises from problems that cannot be solved by existing routine rules and methods of action.

By the second decade of the 21st century, a set of attributes characterizing the fire safety paradigm of buildings was formed (Fig. 1), which included basic groups of factors, such as:



Fig. 1. Building fire safety attributes

### – Fire Safety Environment

The buildings are embedded in a specific urbanization and natural context, which determines the conditions for ensuring fire safety, for example, the vicinity of other buildings, access roads for the fire brigade, the proximity of green areas (forests, meadows), which in times of drought pose an additional fire hazard, and the foundation of buildings in seismic areas or mining areas (semi-seismic).

### – Fire Safety Parameters

The conditions for ensuring fire safety of a building are determined by its intended use (e.g. hospital, kindergarten, penitentiary facility, residential building, production building of combustible products [i.e. sugar factory] or warehouse for flammable substances), and architectural and structural features (e.g. high-rise buildings, large-volume buildings, equipped with atriums or green facades), not only in relation to evacuation conditions, effectiveness of firefighting action, threat to rescue services and potential scenarios of occurrence and dynamics of fire development, but in particular to the control of the spread of fire and smoke in a building structure.

### – Fire safety providers

In contrast, in the process approach, there are interested parties, which include users and managers of buildings, local and state administration, fire brigades and other services (e.g. medical ones), representatives of science, the judiciary, architects, engineers and designers. On the other hand, in the case of cultural goods constituting national or world heritage, it is the whole of society, and on a global scale, humanity. It is necessary to consider not only the safety of people but also the protection of property, including not only the aforementioned cultural goods but also the often-overlooked livestock, the possibility of restoring business activities, and protection of the natural environment.

### – Criteria for determining the existence and development of entities

This group includes all types of descriptive and numerical criteria values that are considered, depending on the need, as permissible limits (e.g. critical temperature of steel or maximum permissible concentration of CO, CO<sub>2</sub> and other toxicants in the air on the escape route), or the minimum expected value (e.g. fire resistance of a building element) or functionality (e.g. fire insulation of a building envelope). These criteria are closely related to the aforementioned groups of fire safety assurance entities.

This is not a closed set because of the progressive development of knowledge and technology in relation to ensuring the fire safety of buildings.

Currently, the dominant framework of the ideas, or rather the main objectives of fire safety in relation to buildings and other construction objects, are defined as follows:

- Fire prevention;
- Control and containment of fire spread by means of compartmentalization (fire resistance);
- Fire suppression;
- Reduction of fire damage.

However, the components of the fire safety paradigm of buildings form a complex structure (system) that can be presented

## A paradigm for building fire safety

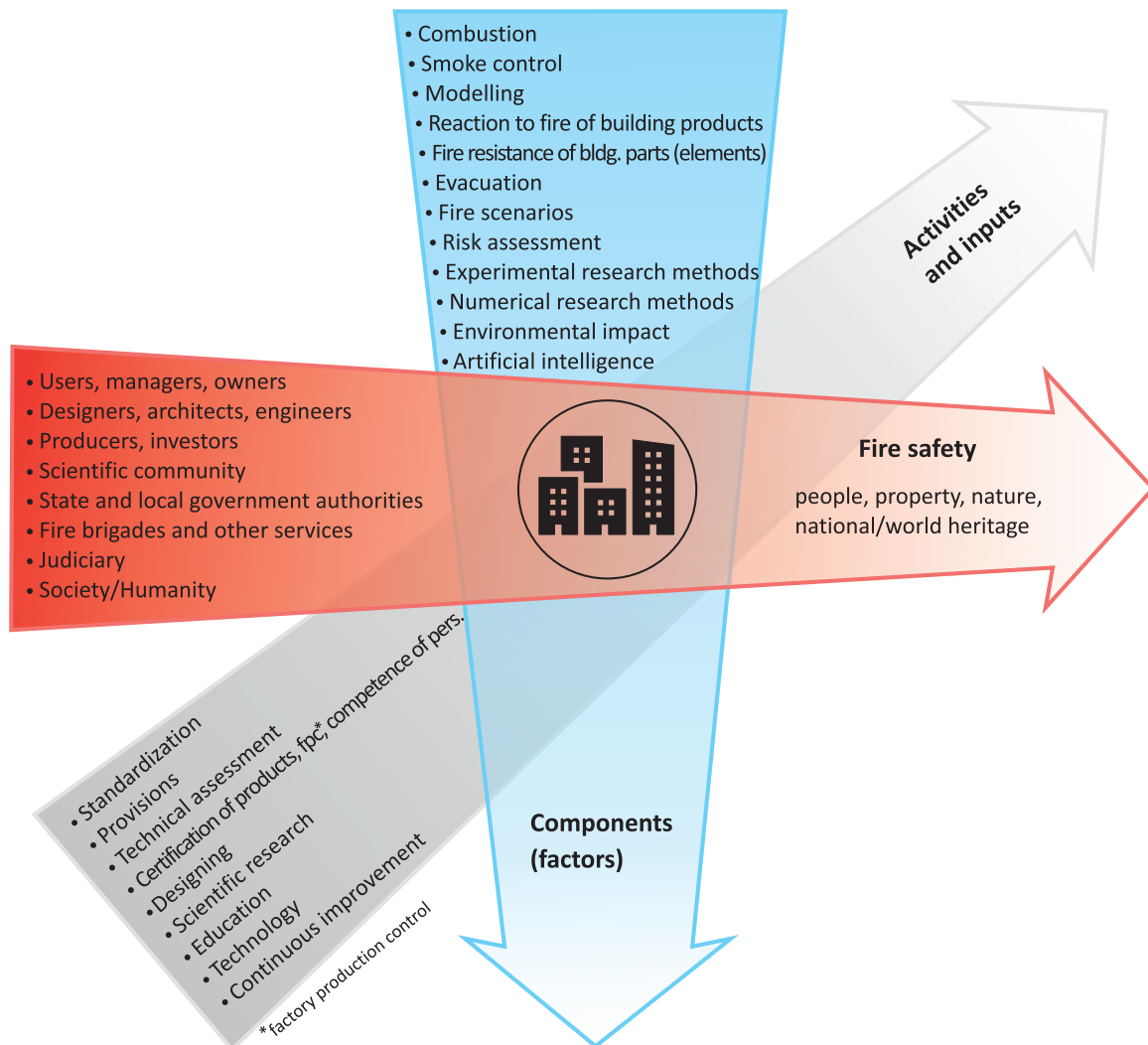

Fig. 2. Schematic diagram of the fire safety paradigm of buildings

graphically (Fig. 2) to illustrate the interconnections and interactions between them.

This structure was built by analogy with a three-dimensional coordinate system using linguistic quantities. Currently, it is not yet possible to assign a sequence of numbers representing the coordinates of a point in the space of this system. However, as knowledge progresses, it will become possible to parameterize the individual elements of this spatial structure (function) on this canvas in the future. The three axes of this system determine the major groups of paradigm elements:

- Fire safety;
- Components;
- Activities and inputs.

For each group, the components were distinguished and then briefly described and characterized, emphasizing their mutual connections and importance for the fire safety of buildings. The order in which the particular elements are listed in Fig. 2 within the three major groups does not reflect their importance for fire safety or the many interrelationships between them, such as modelling and combustion or smoke propagation processes.

### 3. COMPONENTS OF THE PARADIGM

There is rich literature on the individual components of the paradigm, each of which also deserves its own monograph. It was not possible to present detailed data in the form of an article. This chapter is not a review of publications but it presents the author's subjective views on the issues discussed, sometimes illustrated with examples of her own choice.

Fire safety is a highly regulated area in developed countries [9], where there are several legal acts, numerous standards, an established level of technology, specific rules of social coexistence, cultural norms and tradition. Even though, for example, in the European Union countries standards are documents to be used voluntarily, in terms of safety they often become a binding norm. Paradoxically, where there are no detailed legal regulations, there is an expectation on the part of market operators that this gap will be filled by a reliable expert publication.

In a fire, the combustion reaction results in the release of chemical compounds and energy in an uncontrolled and unorganized manner. The formation of these combustion products has a negative and aggressive impact on the structure, people

and environment, but simultaneously triggers countermeasures in the form of human reactions (intervention and evacuation).

People, property and the environment are fire safety entities with their own characteristics (Fig. 1). Each of these elements can have different meanings, depending on the background. While the protection of human life and health, including rescue teams, should always have the highest priority, the protection of property may be important only in specific cases, for example, in relation to cultural goods such as museums, art galleries, and historical buildings.

For the purposes of this study, it was assumed that the fire safety of a building is a set of features related to the location of the building; the use of architectural solutions; the materials, products and elements used; and the equipment with technical means affecting the limitation of the possibility of fire, its development and effects. The fire process itself is so complex that in fire safety studies, it becomes unrealistic to achieve the ability to quantify all the variables necessary for the design or estimation of performance at a level of accuracy that would lend credibility to the use of these calculation results [10].

Knowledge about combustion in fires is not complete and requires further research, despite the fact that there is a rich literature in this area, among others [11–13]. On this basis, it can be concluded that flameless fires (smoldering and incandescence) have aroused growing interest among researchers, who draw attention to their underestimated importance for fire safety. They should be considered, even if they are not a major but a secondary problem in the fire safety of buildings. They are mainly concerned with insulation materials, air gaps, and building equipment such as upholstered furniture, bedding and computers. There is also evidence of the particular importance of smoldering and glowing for the fire and explosion safety of industrial buildings, where large quantities of organic dust are routinely generated (e.g. mills, sugar factories and mines).

When a fire occurs, there is a feedback loop that consists of the interaction of the structure, people and extinguishing measures taken to stop the combustion process. Therefore, fire safety can only be quantified if the combustion process is modelled considering the environment in which it occurs. This is the essence of what we call fire modelling.

The simplest form of the fire model is the detailed fire regulations formulated in the descriptive-prescriptive convention. To this end, various tools are used to assess the extent to which derogation can be applied without running the risk of exceeding acceptable performance limits. These factors include tests of fire properties in terms of ignition, heat of combustion, rate of fire spread, and rate of heat and smoke release. Once the scope of a potential change is defined, a classification that outlines the potential extent to which the solution can be applied emerges. Therefore, the key to design based on specific regulations is classification. If a designer follows specific rules that fall within the scope of the legal regulations that define a known solution leading to the right outcomes, then other sets of rules that implement a separate solution can ensure that the requirements are met. Extrapolation allows the use of a solution that falls within the limits of the classification but deviates from the existing regulations. Fire models can accurately reflect an event,

and their results are physical parameters such as flow velocity, temperature, heat release rate, gas concentration, stresses, displacements, deflections, etc. In this group of models, all the basic processes accompanying the fire phenomenon were considered. There is extensive literature on the development of fire models (for instance: [11, 14]), their predictability, and the different types of validation for many fire scenarios, which is beyond the scope of this study. However, scenario adoption was a separate issue (Fig. 3). The selection of fire scenarios is an essential part of understanding fire dynamics to improve safety in any facility, not just buildings. The set of potential fire scenarios was very large and practically endless. This is because the processes of combustion, flame and smoke spread in buildings are uncontrolled and unorganized. Attempts have been made to control them using various techniques, and to some extent, it is possible to direct these phenomena; however, the condition for a positive effect is the correct design of the system and its proper execution. It is not uncommon for these systems to fail not only because of design or manufacturing errors but also because of improper maintenance and supervision.

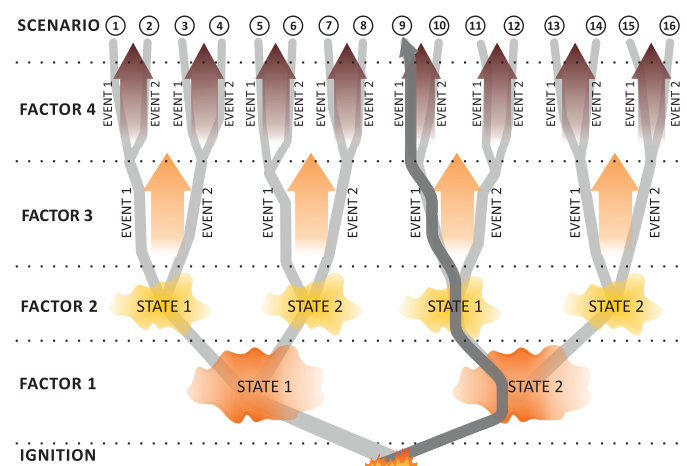
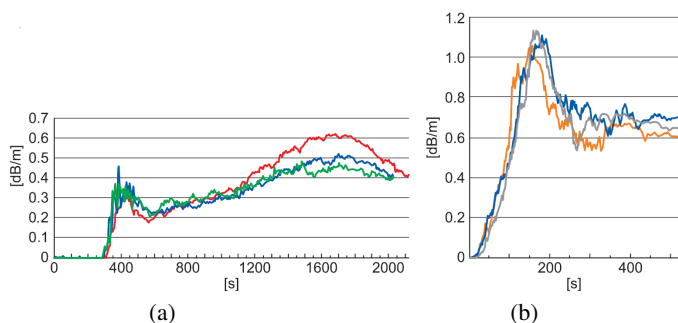

Fig. 3. An example of a fire event tree (the grey arrow indicates the single fire scenario No. 9)

The type and intensity of smoke are closely related to the type and layout of the building and the combustible products present therein, which have an impact on the course of the fire and the resulting combustion products that create smoke that reduces visibility. Despite a properly designed smoke extraction system and evacuation (emergency) lighting system in the building, in accordance with the applicable requirements, the level of expected lighting intensity on the escape route may not be achieved because of the unforeseeable risk of smoke in a given space at this stage [15], which hinders evacuation and rescue operations. The degree of attenuation of the intensity of emergency lighting observed over a wide range is largely dependent on the characteristics of the emitted smoke, which in turn depends on the type of material or product being burned. A derivative problem is the efficiency and activation time of fire detectors and alarm systems. A comparison of the smoke concentration profiles for beech wood (Fig. 4a) and PU foam (Fig. 4b) showed significant differences in smoke emissions for both materials [16]. In the





**Fig. 4.** Smoke concentration in a test chamber with the following dimensions: 9.5 m × 9.7 m × 4.1 m (W×L×H), as a function of time, measured with an optical densitometer for 3 samples of: (a) beech wood, (b) PU foam [16]

case of beech wood, the maximum values for all tested samples were recorded after 26 min of testing, whereas in the case of polyurethane foam, smoke concentration values twice as high as compared with beech wood were obtained in less than 3 min. It should be noted that smoke is a carrier of toxic fire effluents, and statistics show that the vast majority of fire victims die or suffer serious injuries not as a result of thermal impacts but as a result of poisoning with toxic gases, including those originating from plastics [17, 18]. Fire in a building can occur in different ways, depending on the conditions and circumstances. Considering that under certain conditions, even a second-order problem may become the most important one, it is not appropriate to neglect the risk posed by unusual situations, for example, flameless fires; therefore, at an early stage of designing the fire safety of buildings, it is necessary to consider as many fire scenarios as possible, including smoldering, and to estimate their relative risk for further analysis. Not all events that can affect the dynamics of fire development can be predicted; however, there are some pattern events for fires in rooms and buildings. The effects they can cause are listed as known (Table 1). Among the many variants of the course of a fire, various states and sequences of events may occur from the moment of ignition, which will subsequently determine its future course.

**Table 1**

Typical fire events and their results of simulation

Event	Effect
flashover	rapid acceleration to the developed phase
low level of hot layer	accelerating the growth of fire
activation of the automatic fire suppression system	extinguishing or transitioning to a steady phase
manual fire extinguishing	extinguishing or transitioning to a steady phase
fuel depletion	extinguishing
changes in ventilation	modification of fire characteristics
falling burning droplets/particles	another ignition or series thereof

They can all be presented graphically as a fire event tree (Fig. 3). In the event that the combustible content of the building is well-defined and does not change during its use, the combustion characteristics of this content can be assumed as a design fire. The characteristics of the heat release rate of numerous typical construction products and building equipment have been studied in many laboratories using devices operating on the principle of oxygen depletion calorimetry. Tests of this type are the subject of standardization activities and consist mainly of burning a given product or object under a properly instrumented hood under conditions of good ventilation [19].

In real fires, the combustion characteristics of some objects, for example, furniture, can significantly exceed those obtained under laboratory conditions, as a result of preheating the object under the influence of thermal radiation of the hot ceiling layer. As a result, real fires can be less well-ventilated than fires under controlled laboratory conditions, resulting in more smoke and toxic exhaust fumes. In fire safety engineering calculation methods, some estimates depend on the assumed rate of fire growth. This applies primarily to escape routes, particularly when using smoke control systems, as well as to the calculation of the fire resistance of structural components. During the design phase of fire protection and evacuation systems in buildings, one of the fundamental assumptions is the size of the fire for which the facility is designed. This is the most likely and dangerous fire that can be predicted based on the type and location of the fuel(s) in the facility. This fire scenario was accepted as the design scenario.

The occurrence of combustible products is usually eliminated on escape routes or their use on the facades and roofs of buildings is limited. One of the most consistent and logically systematized systems for the assessment and classification of construction products in terms of fire performance is the European system established mainly by the multipart standard EN-13501, which is the basis for construction product evaluation in terms of fire. This system has existed in the EU for more than three decades. This is a sufficient period to gather experience and prompt a retrospective look, summaries and evaluation of functioning. However, this is not a simple conclusion, which is why this issue is illustrated graphically using examples (Fig. 5). The first

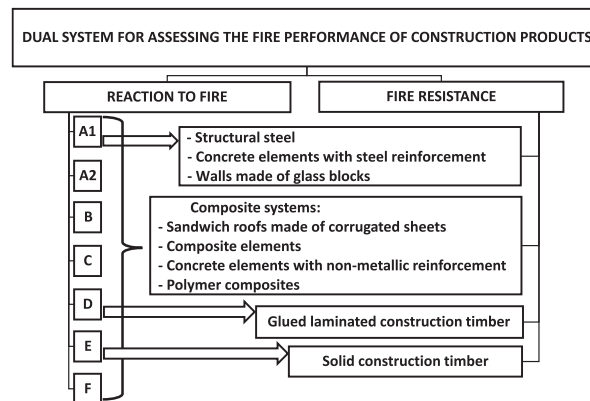

**Fig. 5.** Dual EU system for assessment of fire performance of products used in buildings. Symbols A through F are the main classes of reactions to fire of construction products in the European system

part of EN-13501 concerns the reaction of products to fire [20], and the second concerns fire resistance of construction products and building elements, excluding ventilation systems [21]. The following parts concern utility installations in buildings, for example, ventilation ducts, fire shut-off dampers and smoke control systems. However, it should be noted that the coexistence of the two divisions of product assessment (classification) systems (Fig. 5) under the conventional names of REACTION TO FIRE and FIRE RESISTANCE results in the same product or material being tested, evaluated and classified several times. Consequently, the total number of tests and assessments is multiplied before the evaluation of the product to determine its potential use in the building. The same product, assessed in terms of reaction to fire, after being incorporated into a building element (load-bearing or non-load-bearing) such as a beam, column, roof covering, curtain, partition wall, etc., is again evaluated using different methods and under different test conditions, this time in terms of fire resistance of building elements. As a result of the latter assessment, the scope of product use may be significantly reduced. From the manufacturer's point of view, this process is far from cost-efficient as well as time-consuming. It also delays development and technological progress.

This issue can be discussed in more detail using examples, such as structural steel, glass, composite systems, composites, structural timber, and traditional and modern thermal and acoustic insulation products. This is the subject of ongoing research.

Unfortunately, this system contains very important vulnerabilities that should be classified as paradigm anomalies (Section 4).

The key conditions for achieving the assumed level of fire safety of buildings are activities and expenditures such as standardization, education, technology development, assessment, and certification systems preceding the introduction of construction products to the market and certification of persons. Standardization activities are crucial for fire safety owing to the setting of standards and the unification of concepts, which contributes to the elimination of barriers to the movement of up-to-date knowledge, goods, services and workers at both the local and regional levels, or between economic sectors, but also at the international level. Standardization activities, due to their mode, consolidate a certain existing level of development of knowledge and technology, blocking and delaying the introduction of innovation. This is probably a necessary cost to maintain a certain level of safety; however, to ensure rapid development, standardization procedures should be optimized.

It is also difficult to overestimate the importance of fire-safety education. The development of an educational initiative at the secondary and tertiary levels consistent with education in the field of sustainable construction, for example, [22], is a necessary condition for continuous growth in order to achieve an appropriate level of knowledge about the fire safety of buildings in the coming decades.

The rapid development of artificial intelligence (AI) technology, which is now entering fire safety, for example, multimodal research, will undoubtedly contribute to a paradigm shift in the near future [23]. In addition, in the light of the current and future design and expansion of space stations (e.g. the mission to Mars)

– sooner or later – space engineers will have to face and solve new, as yet undefined problems of fire safety in environmental conditions with low oxygen content and microgravity.

Under the EU system, manufacturers must assess and declare their performance before placing a product on the market. Simultaneously, they should consider potential variability of properties over time, which may affect the safety of the products in their subsequent use. Hence, they should shape the performance parameters of the materials so that they are as constant as possible throughout their long life cycle. This also includes parameters related to ensuring safety in connection with the possibility of construction disasters caused by phenomena such as floods or fires.

The critical case discussed below focuses on the problems that have arisen at the intersection of sustainable development and fire safety of buildings.

#### 4. EXAMPLE OF PARADIGM ANOMALY

There is a significant gap in the systemic approach to fire safety in the EU, as illustrated by the following example. This clearly demonstrates the need to link sustainability and fire safety requirements. In the European system, the issue of flame propagation inside buildings is reflected relatively well. However, a significant gap is the problem of flame spreading on building facades, i.e. outside the external walls. This phenomenon is extremely unfavorable for the fire safety of buildings and their complexes because of the possibility of spreading the fire to other floors in the building or to neighboring buildings. An example is the spectacular fire at the Grenfell Tower Social Building in London in 2017, probably initiated by an electrical failure on the fourth floor. According to official data, 72 people died and 74 were injured in a fire. Many people were trapped on the upper floors, with no means of evacuation, cut off from support of the fire brigade. In only 18 min, the fire spread across the building's facade through 20 floors, reaching the roof. Investigations after the fire showed that the main cause of the rapid spread of the fire, the toxic impact on people of a significant amount of smoke emitted and falling burning parts were design and execution errors in the building's facade during the revitalization carried out in 2015–2016 [24]. Based on the analysis of this catastrophic fire, the authors formulated a postulate to expand the information made available about the product and pointed to the need for systemic thinking: "Systems thinking is necessary to understand the facade components as parts of a system and consider their interactions with each other and their surroundings over time. In addition, it is essential to understand the interactions between various design strategies for sustainability, such as energy-efficient solutions and fire safety requirements".

At the design stage, composite cladding panels were chosen for the cladding of the exterior wall, in which an epoxy resin-based plastic core was used between two layers of thin metal sheets.

It is worth mentioning here that a similar product was not approved for use in Poland in the first decade of the 21st century

because it did not meet the requirements of the original Polish method of testing the spread of fire on the external surface of external walls [25–27], developed in the Fire Research Department of the Building Research Institute in Warsaw at the end of the 1980s.

The procedure for examining and classifying the exterior walls of buildings on the external side in terms of fire spread is provided in the Polish Standard PN-B-02867:2013-06 [25] (Fig. 6), whereas the evaluation of the exterior walls of buildings on the internal side is covered by the European classification system according to EN 13501-1 [20].

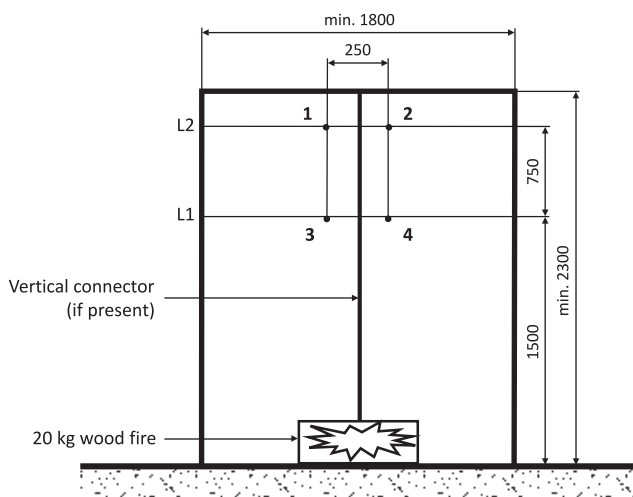

Fig. 6. Test setup according to standard; scheme based on [25]

The standard [25] does not apply to walls in which each separate component has a fire reaction class of at least A2-s3,d0; such walls are considered to be non-spreading fires without testing. Specimens of size 1.8 m (width)  $\times$  2.3 m (height), representative of classified exterior walls, were exposed to a standard 20 kg wood fire under conditions corresponding to the initial period of fire development. The flame propagation range, temperature rise and visual observations were recorded during the test. The testing conditions were as follows: (1) temperature  $20 \pm 10^\circ$ , (2) no rain, ice rain, or frost, and (3) wind speed of up to 2 m/s. An electric ventilator was used to obtain the required wind speed. The testing period was 30 min (15 min fire exposure and 15 min observation). The specimens were conditioned to  $15 \pm 10^\circ\text{C}$  prior to testing. Proper visual observation should be performed, and photographs should be taken during and after the test.

This indicates that with relatively simple solutions and small outlays, it would be possible to remove the indicated paradigm anomalies by meeting the requirement of assessing products for building facades in terms of fire propagation on external walls. A similar addition must be made in the formulation of fire toxicity requirements for construction products other than electrical cables, which are currently the only product thus regulated. In this way, many of the injuries sustained in fires could have been avoided, and many lives lost in fires, such as those described above, could have been saved.

## 5. CONCLUDING REMARKS

The role and significance of the fire safety paradigm of buildings in the development of fire safety science is closely related to the development of sustainable construction on regional and local scales. These two issues are consistent and should not be treated separately. The analysis presented herein shows the need to change the approach to fire safety issues in buildings, primarily because of the following:

- reducing the consumption of natural resources (e.g. natural aggregates and water) by replacing them with flammable additives such as synthetic polymers and wood;
- increasing the thickness of insulation and tightness of the building envelope, as well as increasing the share of complex products and systems (multi-material, multi-layered) with flammable layers, resulting from the need to meet the growing requirements of energy efficiency;
- an increase in the use of waste materials (recycling), which is usually characterized by an increased content of organic (combustible) parts;
- the need to control the risk of fire (i.e. the level of fire safety assurance), which is not always adequate for the results of tests of materials and components of individual construction products as well as structural and non-structural elements of buildings;
- the negative impact of fires on the natural environment, primarily through the release of  $\text{CO}_2$  and many other toxic and irritating compounds into the atmosphere, as well as contamination of water resources.

A paradigm shift will result in the introduction of a fire toxicity criterion for the assessment of construction products, which, for unknown reasons, has so far only been implemented in relation to cables. The second necessary amendment is the addition of a requirement for the spread of fires on building facades.

However, the development of artificial intelligence (AI) technology may cause a scientific revolution in the fire safety of buildings. At present, it is not possible to clearly indicate the direction of future changes because the number of publications on AI technology in construction is still too small.

At this point, it is justified to state that the paradigm described is universal, and its universality is based on the possession of certain common attributes characteristic of the fire safety environment and their interpretation, as well as the manner in which fire safety entities implement them. The overall concept of fire safety is not uniform, as it is subject to changes resulting from the changing conditions of the environment and entities participating in the fire safety assurance process on local, regional, national and international scales.

The paradigm described in this article is so universal that the anomalies mentioned above will not require a significant change, but only supplementation.

## ACKNOWLEDGEMENTS

The author would like to acknowledge the support from internal project No. NZP-153 of the Building Research Institute (ITB) in Warsaw, Poland. Moreover, the author would like to

thank Professor L. Czarnecki for the valuable discussions, and Mr. M. Gębarzewski for his technical support in preparation of Figs. 2 and 3.

## REFERENCES

- [1] T.S. Kuhn, *The Structure of Scientific Revolutions*, Chicago, IL, USA: UChi Press, 1962.
- [2] Ł. Sadowski, J. Hoła, L. Czarnecki, and T.G. Mathia, “New paradigm in the metrology of concrete surface morphology: Methods, parameters and applications,” *Measurement*, vol. 169, p. 108497, 2021, doi: [10.1016/j.measurement.2020.108497](https://doi.org/10.1016/j.measurement.2020.108497).
- [3] J. Gryz, “Współczesny paradygmat bezpieczeństwa międzynarodowego. (The Contemporary Paradigm of International Security),” *Rocznik Bezpieczeństwa Międzynarodowego*, Wrocław, Poland, 2006, pp. 12–27, doi: [10.34862/rbm.2006.2](https://doi.org/10.34862/rbm.2006.2) (in Polish).
- [4] D. Morgan, “Paradigms lost and pragmatism regained: methodological implications of combining qualitative and quantitative methods,” *J. Mixed Methods Res.*, vol. 1, no. 1, pp. 48–76, 2007, doi: [10.1177/2345678906292462](https://doi.org/10.1177/2345678906292462).
- [5] V. Babrauskas, “Some neglected areas in fire safety engineering,” *J-STAGE*, vol. 32, no. 1, pp. 35–48, 2023, doi: [10.3210/fst.32.35](https://doi.org/10.3210/fst.32.35).
- [6] Regulation of the European Parliament and of the Council (UE) Nr 305/2011 Council of 9 March 2011 laying down harmonised conditions for the marketing of construction products and repealing Directive 89/106/EEC. OJEU, 2011, [Online], Available: <https://isap.sejm.gov.pl/WDU20210001213> [Access: 04.01.2023].
- [7] Accelerating the Development of the Sustainable Construction Market in Europe, COM-860, 2007, [Online], Available: <https://commission.europa.eu/strategy-and-policy/priorities-2019-2024/european-green-deal> [Access: 03.02.2024].
- [8] L. Czarnecki and M. Kaproń, “Sustainable Construction as a Research Area,” *Int. J. Soc. Mater. Eng. Resour.*, vol. 17, no. 2, pp. 99–106, 2010, doi: [10.5188/ijmsmer.17.99](https://doi.org/10.5188/ijmsmer.17.99).
- [9] M. Abramowicz and R.G. Adamski, *Bezpieczeństwo pożarowe budynków. Część I. (Fire safety of buildings. Part I)*, SGSP, Warszawa, Poland, 2002 (in Polish).
- [10] M. McLaggan *et al.*, “Towards a better understanding of fire performance assessment of façade systems: Current situation and a proposed new assessment framework,” *Constr. Build. Mater.*, vol. 300, p. 124301, 2021, doi: [10.1016/j.conbuildmat.2021.124301](https://doi.org/10.1016/j.conbuildmat.2021.124301).
- [11] D. Drysdale, *An introduction to fire dynamics*. New York, USA: Wiley, 2011.
- [12] J.G. Quintiere, *Fundamentals of Fire Phenomena*, New York, USA: Wiley, 2006.
- [13] V. Babrauskas, *Ignition Handbook*, Issaquah, USA: Fire Sci. Pub., 2003.
- [14] G. Cox. *Combustion Fundamentals of Fire*. London, UK, San Diego, USA: Academic Press, 1995.
- [15] W. Węgrzyński, P. Antosiewicz, and J. Fangrat, “Multi-Wavelength Densitometer for Experimental Research on the Optical Characteristics of Smoke Layers,” *Fire Technol.*, vol. 57, pp. 2683–2706, 2021, doi: [10.1007/s10694-021-01139-5](https://doi.org/10.1007/s10694-021-01139-5).
- [16] P. Antosiewicz and J. Fangrat, “Wpływ warunków pożarowych na natężenie oświetlenia ewakuacyjnego (Influence of fire conditions on illuminance of evacuation lighting),” in *Proc. XXVII KKO Tech. Światlna*, Poland, 2018 (in Polish).
- [17] T.R. Hull and A. Stec, “Introduction to Fire Toxicity,” in *Fire Toxicity* T.R. Hull, A. Stec, Eds., Cambridge, UK: Woodhead, 2010, pp. 1–25, doi: [10.1533/9781845698072.1.3](https://doi.org/10.1533/9781845698072.1.3).
- [18] K. Kaczorek-Chrobak and J. Fangrat, “PVC-Based Copper Electric Wires under Various Fire Conditions: Toxicity of Fire Effluents,” *Materials*, vol. 13, no. 5, p. 1111, 2020, doi: [10.3390/ma13051111](https://doi.org/10.3390/ma13051111).
- [19] X. Huang *et al.*, “A global model for heat release rate prediction of cable burning on vertical cable tray in different fire scenarios,” *Fire Technol.*, vol. 58, no. 5, pp. 3119–3138, 2022, doi: [10.1007/s10694-022-01304-4](https://doi.org/10.1007/s10694-022-01304-4).
- [20] EN 13501-1 Fire classification of construction products and building elements – Part 1: Classification using test data from reaction to fire tests. CEN, Brussels.
- [21] EN 13501-2 Fire classification of construction products and building elements – Part 2: Classification using data from fire resistance tests, excluding ventilation services. CEN, Brussels.
- [22] “Masters’ by Research in Sustainable Construction & Infrastructure. University of Strathclyde,” [Online], Available: <https://www.strath.ac.uk> [Access: 12.03.2024].
- [23] T. Zhang, F. Ding, Z. Wang, F. Xiao, C.X. Lu, and X. Huang, “Forecasting Backdraft with Multimodal Method: Fusion of Fire Image and Sensor Data,” *Eng. Appl. Artif. Intell.*, vol. 132, p. 107939, 2023, doi: [10.1016/j.engappai.2024.107939](https://doi.org/10.1016/j.engappai.2024.107939).
- [24] S. Bahrami and D. Zeinali, “The sustainability challenge of product information quality in the design and construction of facades: lessons from the Grenfell Tower fire,” *Smart Sustain. Built Environ.*, vol. 12, no. 3, pp. 488–506, 2023, doi: [10.1108/SASBE-06-2021-0100](https://doi.org/10.1108/SASBE-06-2021-0100).
- [25] PN-B-02867:2013-6 Ochrona przeciwpożarowa budynków. Metoda badania stopnia rozprzestrzeniania ognia przez ściany zewnętrzne od strony zewnętrznej oraz zasady klasyfikacji (*Fire protection of buildings. Method of testing the fire spread rate over external walls from the outside and classification rules*), PKN, Warszawa, Poland (in Polish).
- [26] J. Fangrat and M. Kosiorek, “Comparison of large and bench scale test results for external wall linings”. In: Fire safety science, M. Curtat, Ed., *Proc. 6th Int. Symp.*, France, 2000, p. 1232.
- [27] J. Fangrat, “Poland,” in *Plastics flammability handbook: Principles, regulations, testing, and approval*. J. Troitzsch and E. Antonatus, Eds., Munich, Germany, Cincinnati, OH, USA: Hanser, 2021, pp. 360–368.