

A Precise and High Speed Charge-Pump PLL Model Based on SystemC/SystemC-AMS

Kezheng Ma, Rene van Leuken, Maja Vidojkovic, Jac Romme, Simonetta Rampu, Hans Pflug, Li Huang, and Guido Dolmans

Abstract—The Phase Locked Loop (PLL) has become an important part of electrical systems. When designing a PLL, an efficient and reliable simulation platform for system evaluation is needed. However, the closed loop simulation of a PLL is time consuming. To address this problem, in this paper, a new PLL model containing both digital and analog parts based on SystemC/SystemC-AMS (BETA version) is presented. Many imperfections such as Voltage Control Oscillator (VCO) noise or reference jitter are included in this model. By comparing with the Matlab model, the SystemC/SystemC-AMS model can dramatically reduce simulation time. Also, by comparing with Analog Devices ADI SimPLL simulation results, Cadence simulation results and real measurement results, the accuracy of the SystemC/SystemC-AMS model is demonstrated. The paper shows the feasibility of a unified design environment for mixed-signal modelling based on SystemC/SystemC-AMS in order to reduce the cost and design time of electrical systems.

Keywords—SystemC/SystemC-AMS, Phase Locked Loop (PLL), radio frequency, mixed-signal modeling, hardware description language.

I. INTRODUCTION

PHASE Locked Loops (PLL) have become an important part of electrical systems. It is widely used in radios, computers, telecommunications, and other electronic applications. However, when designing a PLL, one of the main problems is that the closed loop simulation of a PLL is very time consuming, especially at transistor level. For example, a fine frequency resolution required in noise simulation often leads to an over 24-hour simulation time [1]. Therefore, to examine the closed loop behavior, a fast and precise model is highly desirable.

Many efforts have been spent to address this problem, such as in [1] and [2] where Verilog-AMS models are presented. However, these models have their limitations in terms of simulation performance. For instance, in [1], the high frequency output of the Voltage Control Oscillator (VCO) is not generated in order to reduce simulation time. But in this way, it is impossible to insert the PLL into a radio system model for further testing. In [2], although the VCO output is generated, performing a 60us transient analysis requires 15 minutes. Consequently, the simulation time will be over 4 hours if a transient analysis over 1000us (for noise analysis) is needed.

Rene van Leuken is with Delft University of Technology, Mekelweg 4, 2628 CD Delft, Netherlands. All other authors are with Holst Centre, HTC 31, 5656 AE, Eindhoven, Netherlands (e-mails: mkz1986@hotmail.com; t.g.r.m.vanleuken@tudelft.nl; simonetta.rampu@gmail.com; {Maja.Vidojkovic; Jac.Romme; Hans.Pflug; Li.Huang; Guido.Dolmans}@imec-nl.nl).

To further improve simulation time while still keeping good accuracy, a new mixed-signal PLL model based on SystemC/SystemC-AMS (BETA version) is proposed in this paper. Unlike many other high center frequency models, the model in this paper does not combine the divider and the VCO. Consequently, the high frequency VCO output is available, which enables designers to insert the PLL into a radio system model to evaluate the overall system performance. In the past, we published one paper on SystemC/SystemC-AMS PLL model [3]. However, this model only has basic functionality and includes limited practical imperfections. To develop a more realistic model for system design, many imperfections are included in the model proposed in this paper, e.g. VCO noise, PLL Dead Zone, Phase Frequency Detector (PFD) reset delay, Charge Pump (CP) current mismatch, CP leakage current, the reference jitter and Delay difference between the CP control signal. The simulation results of the proposed model are compared with the simulation (measurement) results of a Matlab model, Analog Devices ADI SimPLL tool, Cadence, and real chip implementation. The comparison results verify that the SystemC/SystemC-AMS model is precise with fast simulation time.

The paper is organized as follows. The SystemC/SystemC-AMS language is briefly introduced in section II. The structure of the model is discussed in section III. The behavioral modeling of each PLL block is shown in section IV. Our proposed model is verified in section V. Finally, conclusions are given in section VI.

II. INTRODUCTION TO SYSTEMC/SYSTEMC-AMS

SystemC/SystemC-AMS is an effective system-level simulation and modeling language. It has many advantages. First of all, it is a C++ based language which ensures fast calculation speed. Moreover, it can take advantage of C++ power by using a large number of existing C++ functions and libraries. Secondly, SystemC/SystemC-AMS support hardware and software co-design which is very important to the design of a very complex system. Last but not least, SystemC/SystemC-AMS is an open source language, which requires no license fee for the usage.

A. SystemC

SystemC is a C++ based language. It adds a class library to C++ which enables it to describe hardware. SystemC is able to describe the concepts that are familiar to hardware designers, such as signals, modules and ports.

SystemC does not add any new syntax to C++. Instead, it only adds a library class to describe the concepts in hardware design. Thus, SystemC is essentially C++. For this reason, the designers can conveniently use the standard C++ developing tools to simulate, debug and execute all kinds of algorithms and structures. More importantly, with SystemC, a hardware model could be made in system level as well as Register Transfer Level (RTL). We can first make a system level model to simulate and optimize the design quickly. Then we can transfer the design to RTL level for synthesis.

The language structure of SystemC is shown below. In the first part, the input and output ports are defined. The second part illustrates the methods used to describe the function of this module and in the third part, the constructor of the module is presented.

```
SC_MODULE (example) {
  sc_in<double> input1, input2;
  sc_in<bool> input3, input4;
  sc_out<double> output1, output2;

  void prc_example();

  SC_CTOR(example) {
  SC_THREAD(prc_example);
  }
};
```

SystemC is very suitable for modeling the digital circuits. However, its main limitation is the disability of simulating analog or mixed signals. For this reason, SystemC-AMS is introduced as a complement to deal with this inconvenience.

B. SystemC-AMS

In order to simulate the analog circuits, AMS extensions based on SystemC are introduced. The SystemC-AMS extensions are built on top of the SystemC language standard IEEE 1666-2005. They define additional language constructs, which introduce new execution semantics and system-level modelling methodologies to design and verify mixed-signal systems [4]. They can be further divided into three models – Timed Data Flow model (TDF), Linear Signal Flow model (LSF), Electrical Linear Networks model (ELN).

1) *TDF model*: As shown in Fig. 1, the TDF model is a discrete-time model. It considers the data as sampled signals in time. Each TDF model is composed of a number of TDF modules which are connected with TDF signals and TDF ports. In each module, C++ methods are used to describe a function of the module.

2) *LSF model*: The LSF model is a continuous-time module. This model provides a finite number of LSF modules to implement calculation such as addition, subtraction and

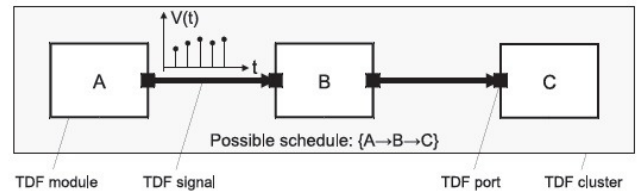

Fig. 1. A TDF model with 3 TDF modules [4].

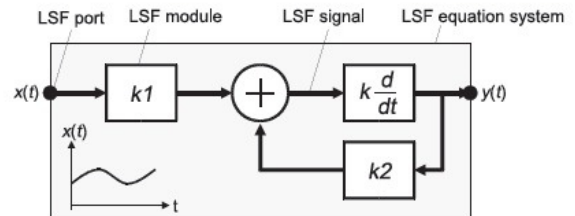

Fig. 2. A LSF model with 4 LSF modules [4].

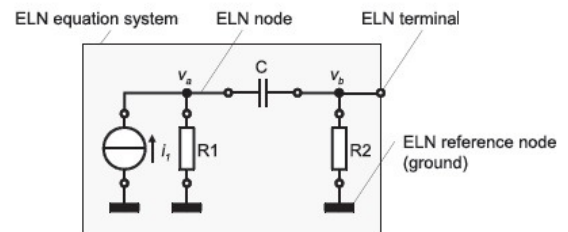

Fig. 3. A basic ELN model [4].

multiplication. The users are not allowed to define their own blocks. In other words, LSF model can only be composed with the provided modules. LSF signals are used to connect the modules. In this way, the equation system will be formed to relate the inputs and outputs. Fig. 2 shows a basic LSF model.

3) *ELN model*: As shown in Fig. 3, in ELN model, a set of electrical primitives such as sources (voltage or current), linear lumped elements (resistors, capacitors, inductors) are provided. Designers model the circuit by connecting these primitives with electrical nodes. The system will follow the Kirchhoff's current and voltage laws. ELN terminals are used to communicate with other models.

C. Simulation Flow

The simulation flow is shown in Fig. 4. The digital parts of the system are modeled with SystemC while the analog parts are modeled with SystemC-AMS. After transient simulations, the generated data will be loaded into Matlab to perform frequency analysis.

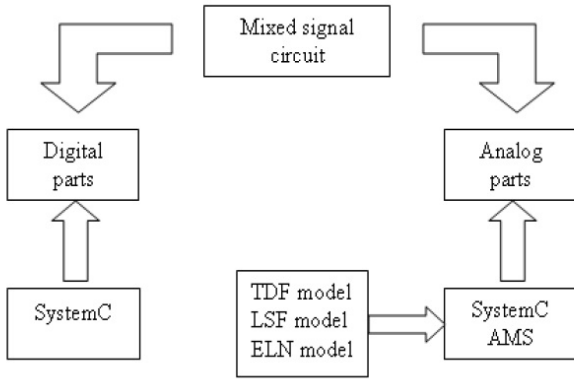

Fig. 4. SystemC/SystemC-AMS model design flow.

III. THE PLL MODEL STRUCTURE

In radio transmitters, an integer N-PLL is used to synthesize new frequencies which are multiples of a reference frequency, with the same stability as the reference frequency. The structure of the integer PLL modeled in this paper is shown in Fig. 5, in which the reference clock block, phase/frequency detector (PFD) block, divider block, rfdelay block are modelled with SystemC and other blocks are modelled with SystemC-AMS.

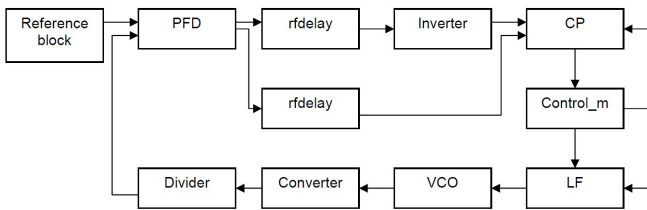

Fig. 5. Structure of the PLL model.

As shown in the figure, the model is composed of eleven blocks, a reference clock block, a phase/frequency detector block, two rfdelay blocks, an inverter block, a charge pump block, a control_m block, a loop filter (LF) block, a voltage control oscillator block, a converter block and a divider block. The reference clock block is used to generate reference signal, the PFD block is used to detect the phase/frequency difference between the reference signal and the divider output. After the PFD, the signal goes into rfdelay block and inverter to generate the signals that control the charge pump. The CP will charge the loop filter to generate the VCO control voltage. The control_m block is used to limit the output voltage of the loop filter. The converter block transfers the VCO analog output signal to a digital input signal suitable for the frequency divider.

IV. CIRCUIT MODEL BASED ON SYSTEMC/SYSTEMC-AMS

In this section, the behavior SystemC/SystemC-AMS model of each block of the PLL model will be presented.

A. Reference Clock Block

The reference clock block is used to generate the reference clock of the PLL. It is modelled with SystemC because it is a pure digital block. Part of the source code of reference block is shown below. It works as follows: the period of the reference clock is T , then every $T/2$, the output will reverse its value. The function *gauss()* is used to generate a gauss random number with 0 mean and variance of *jitter* which is used to model the reference jitter.

```
SC_MODULE (reference){
    sc_out<bool> out;

    void prc_reference();

    SC_CTOR(reference){
        SC_THREAD(prc_reference);
    }
};

void reference::prc_reference(){
    out=0;
    while(1)
    {
        out=!out;
        wait(T/2+gauss(jitter), SC_US);
    }
}
```

B. The PFD Block

The structure of the PFD is shown in Fig. 6, it is composed of 2 D-registers, a delay block and an and-gate. The PFD inputs signals, reference clock and divider output, serve as the clock of the registers. The D ports of the registers are connected to the VDD supply. The registers outputs qa and qb are the outputs of PFD. If qa and qb are both 0 and there is a rising edge in reference clock, qa will become 1. If this follows by a rising event in divider output, qb will become 1 and the registers are reset. A delay block is introduced to model the reset-delay. Also it can be used to eliminate the

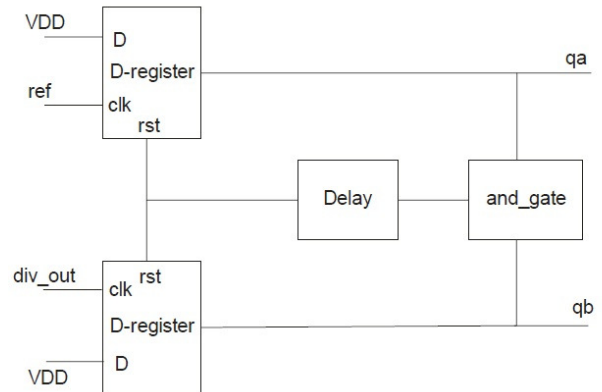

Fig. 6. Structure of the PFD.

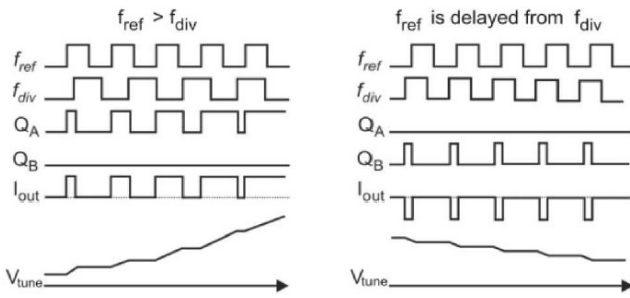

Fig. 7. PFD waveform [5].

dead zone. As shown in Fig. 7, it is clear that the phase and frequency difference is detected. If the reference frequency is larger than that of divider output or reference phase leads to the divider output phase, there is a pulse in q_a and q_b is equal to 0 (maybe with very small pulse because of the reset delay). On the contrary, if the reference frequency is smaller than that of divider output or reference phase delayed from the divider output phase, there is a pulse on q_b and q_a is equal to 0.

C. The Rfdelay Block

Both the rising edge and the falling edge of a digital signal are non ideal, i.e. there is some delay when the signal changes from 1 to 0 or from 0 to 1. If the pulse width of the PFD outputs is too small, the signals value will not reach its peak value. This causes PLL Dead Zone. The rfdelay block is used to model this behavior and it is modelled with SystemC. The code below is part of the source code of this block. It acts as follows: when the input is 1 or 0, the output will increase or decrease gradually (rstep or fstep V per 0.1 ns) until it is larger than VDD or smaller than 0 V.

```
SC_MODULE (rfdelay){
    sc_in<bool> in;
    sc_out<double> out;

    void prc_rfdelay();

    SC_CTOR(rfdelay){
        SC_THREAD(prc_rfdelay);
    }
};

void rfdelay::prc_rfdelay(){
    while(1){
        wait(in.value_changed_event());
        if(in==1)
        {
            b: while(out<vdd){
                out=out+rstep;
                wait(0.1, SC_NS);
                if(in==0){goto a;}
            }
        }
        else
        {
            a: while(out>gnd){
                out=out-fstep;
                wait(0.1, SC_NS);
                if(in==1){goto b;}
            }
        }
    }
}
```

D. Inverter

The inverter is modelled with SystemC, which will reverse the value of its input. It should be noticed that the inverter includes the rising and falling delay, just like the rfdelay block and the modelling method is same. The delay will contribute to the delay difference of the charge pump control signals which will cause reference spurs.

E. Charge Pump and Loop Filter

The structure of the charge pump and loop filter are shown in Fig. 8, the output of the PFD (after the rfdelay and inverter) are connected to gate M_{p1} and M_{n1} , if the frequency of reference clock is larger, the M_{p1} will open and the up current source will charge the loop filter. As a result, the tuning voltage V_{tune} will increase, the VCO output frequency will increase. If the reference frequency is smaller, it will go to the reverse way. The code below is part of the source code of the charge pump. The current source of the charge pump are transistors working in saturation region. When the voltage V_{tune} (v_c here) is larger than min and smaller than max , both pumps work in saturation region, the charge current (charge) and discharge (discharge) current will be equal to the saturation current $currentup$, $currentdw$ respectively. The *mismatch* indicates the

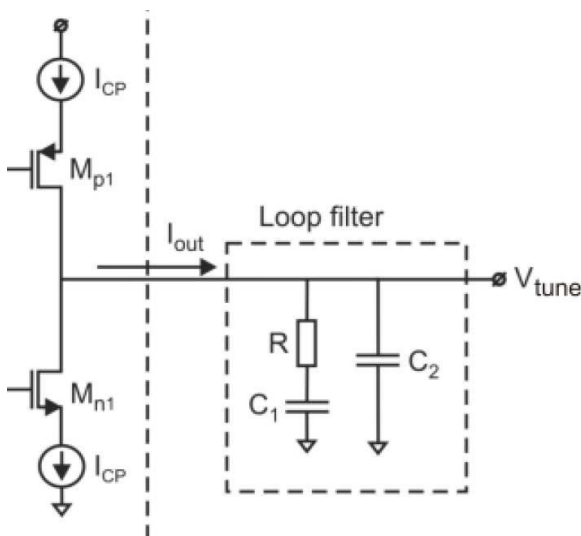

Fig. 8. Structure of charge pump and loop filter [5].

current when both switches are closed which is the charge pump current mismatch. When V_{tune} is smaller than min , the down pump goes to the triode region and the current will be smaller. In the same way, when V_{tune} is larger than max , the up pump goes to the triode region, the up pump current will become smaller. The other imperfection modelled in this charge pump model is the leakage current, when both switches are open, there is still a small negative current exist (*leakage*).

In summary, there are three imperfections modelled in the Charge Pump model, current mismatch, transistor triode region and leakage current. The current mismatch and leakage current will cause the reference spurs. The transistor triode region will result in the increasing of the settling time.

The loop filter is modelled as a second order loop filter with two capacitors and one resistor using the ELN model.

The calculation of the current in the triode region is as follows, we assume the current source is a single transistor current source. So in the saturation region, the current is equal to:

$$I_D = \frac{\mu_n C_{ox} W}{2L} (V_{GS} - V_{TH})^2. \quad (1)$$

where μ_n is the electron mobility, C_{ox} is the dioxide capacitor, W is the width of transistor, L is the length of the capacitor, V_{GS} is gate source voltage and V_{TH} is the threshold voltage.

The current in triode region is:

$$I_D = \frac{\mu_n C_{ox} W}{L} [(V_{GS} - V_{TH})V_{DS} - V_{DS}^2 \div 2]. \quad (2)$$

get $\frac{\mu_n C_{ox} W}{2L}$ from (1) and then replace it in (2), $V_{GS} - V_{TH}$ is equal to 0.9 (which means V_{TH} is 0.3V). Then the solution for triode region current can be calculated. The result is $\frac{20}{9}I_D V_{DS} - \frac{100}{81}I_D V_{DS}^2$ (V_{DS} is the drain source voltage).

```
SCA_TDF_MODULE(charge_pump) {
sc_in<double> a,b;
sca_tdf::sca_in<double> vc;
sca_tdf::sca_out<double> out;
.
.
.
void processing(){
if(vc>min&&vc<max)
{
charge=currentup;
discharge=-currentdw;
mismatch=charge+discharge;
}
else if(vc<min)
{
vds=vc;
charge=currentup;
discharge=-20/9.0*currentdw*vds+
100/81.0*currentdw*vds*vds;
mismatch=charge+discharge;
}
}
```

```
else if(vc>max)
{
vds=1.2-vc;
charge=20/9.0*currentup*vds-
100/81.0*currentup*vds*vds;
discharge=-currentdw;
mismatch=charge+discharge;
}
if(a<thres&&b<thres)
{out=charge;}
else if(a>thres&&b>thres)
{out=discharge;}
else if(a>thres&&b<thres)
{out=-leakage;}
else if(a<thres&&b>thres)
{out=mismatch;}
}
};
```

F. Control_m Mlock

Because the TDF module is based on C++, the voltage has no limitations. In other words, the voltage can go to infinite. The control_m block is used to limit the voltage. When the V_{tune} becomes larger than the supply voltage (vdd) or smaller than 0, control_m will cut off the current from charge pump which prevent the V_{tune} to keep on changing. In this way, the V_{tune} will be limited to the range 0-vdd.

G. VCO

The output of VCO is given by:

$$\cos(\omega_0 \times t + 2 \times \pi \times K_{vco} \times \int vc dt) \quad (3)$$

where ω_0 is free running VCO frequency, K_{vco} is the VCO gain, vc is the control voltage of the VCO (V_{tune}). Also, VCO noise is included in this model, the way to model VCO noise is shown in Fig. 9. A gauss random number generator generates a sequence of random number with 0 mean and variance 1. Then the random numbers are multiplied with a gain $\sqrt{C_{vco}}$ which can be derived from the data sheet of the VCO [6]. After the multiplication, an integrator will integrate the result to change it to phase domain. Finally, the noise is added to the output phase of the VCO.

H. Converter

The PLL model is a mixed signal model and requires the conversion between analog and digital signals. A converter block is used to achieve this function. In the feedback loop, it converts the VCO sine wave output to a square wave which is suitable for the digital divider. It acts as follows, when the sine waves value is larger than 0, the output is equal to 1, if it is smaller than 0, the output is equal to 0.

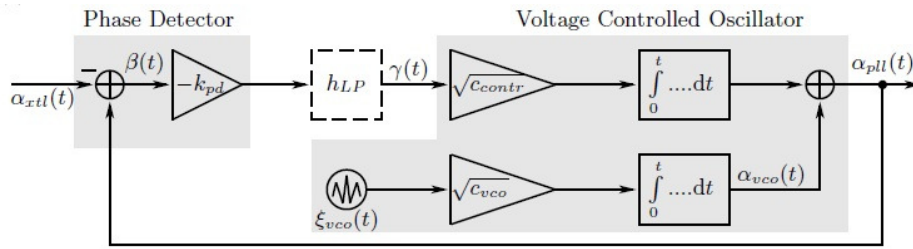

Fig. 9. VCO noise model [6].

I. Divider

The divide N divider is modelled as a counter. If there is an event in the input, a signal *count* will add one. If *count* is larger than a certain number N, the output will be reversed. Part of the divider code is shown below.

```
while(1){
    wait(in.value_changed_event());
    count = count.read() + 1;
    if(count.read() > N)
    {
        out=!out.read();
        count.write(0);
    }
}
```

V. SIMULATION RESULTS

The model proposed in this paper has been used to simulate the integer PLL represented in [5]. The PLL has a reference clock of 500kHz, an output frequency of 2.4GHz, a charge pump current of 50uA. The leakage current is set to 25pA and the charge pump current mismatch is 5uA. The simulation time for 1200us transient analysis with a 0.01ns resolution is about 15 minutes.

To ensure the correctness of the model, the simulation results are compared with the Matlab simulation results, Analog Devices ADI SimPLL simulation results, Cadence simulation results, and the measurement results. The parameter values in ADI SimPLL, Cadence and real circuits are equal to the values mentioned above. When comparing with the Matlab model, the parameters are set as follows: a reference clock of 31.2MHz, an output frequency of 124.8MHz, an up pump current of 25uA and a down pump current of 15uA. The free running VCO frequency is 124MHz.

A. Comparison with Matlab Simulation Results

The simulation results of the SystemC/SystemC-AMS model are first compared with the simulation results of a Matlab model. The Matlab model is a sample-driven simulator for charge-pump PLLs. To shorten simulation-time, the VCO output signal is modelled in the phase domain, such that the frequency division becomes a mere scaling of the phase. The phase noise is modelled as a Gaussian random walk process and the current-source imbalance can be simulated.

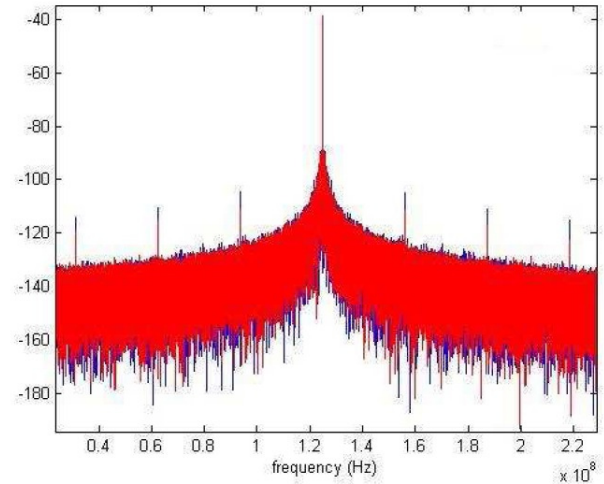

Fig. 10. PSD of VCO output of our and Matlab models.

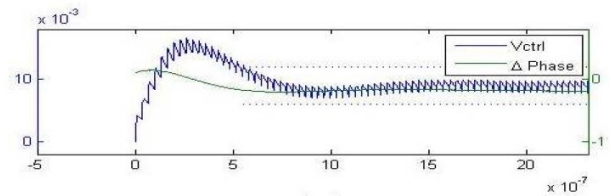

Fig. 11. VCO control voltage of the Matlab model.

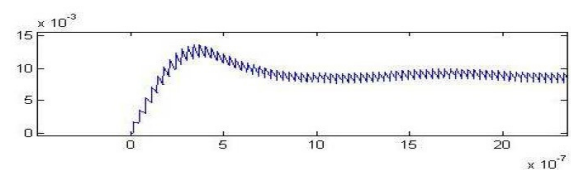

Fig. 12. VCO control voltage of our model.

The two models have the same parameter values and include the same imperfections. Fig. 10 shows the VCO output power spectrum density (PSD) of the two models, in which the red one is the PSD of the SystemC/SystemC-AMS model while the blue one is that of the Matlab model. As shown, the two results are very similar.

Fig. 11 and Fig. 12 show the time domain simulation results of VCO control voltage. The settling time of the Matlab model

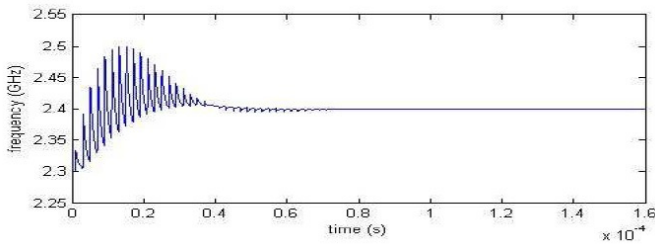

Fig. 13. VCO output frequency of our model.

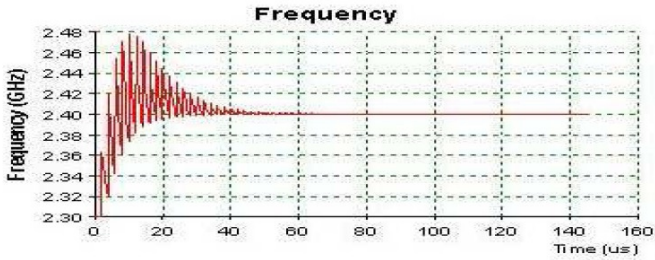

Fig. 14. VCO output frequency of the ADI SimPLL tool.

is about 1.5 us whereas that of the SystemC/SystemC-AMS model is about 1.5 us too. It is clear that our model and the Matlab have comparable simulation results. The simulation time of SystemC/SystemC-AMS model (about 2 minutes for 650 us simulation with a resolution of 0.1 ns) is about 10 times smaller than that of the Matlab model (about 20 minutes for 639 us simulation with a resolution of 0.1 ns).

Another advantage of SystemC/SystemC-AMS over Matlab is its capability to simulate very high frequency signal in a high resolution. For example, for a PLL model with 2.4GHz VCO output frequency and resolution of 0.01ns, SystemC/SystemC-AMS is able to do a 650us simulation while Matlab fails (Matlab will run out of memory).

B. Comparison with ADI SimPLL Simulation Results

The simulation tool ADI SimPLL published by Analog Devices is used to verify the close loop simulation results of the SystemC/SystemC-AMS model. Fig. 13 shows the VCO output frequency of SystemC/SystemC-AMS model and Fig. 14 shows the frequency of the ADI tools simulation result. The parameter values of both are the same. The settling time of both results is about 60 us and the waveforms are comparable. Thus, the closed loop behavior is correctly modelled with SystemC/SystemC-AMS.

C. Comparison with Cadence Simulation Results

The simulation results of the PLL closed loop behavior were verified in the previous subsection. In this section, the open loop simulation results are verified by Cadence simulation results. Fig. 15 and Fig. 16 show the open loop simulation results of Cadence and the SystemC/SystemC-AMS model respectively. The input signals of the two models are the same. In the figure, the first two signals are the outputs of the PFD,

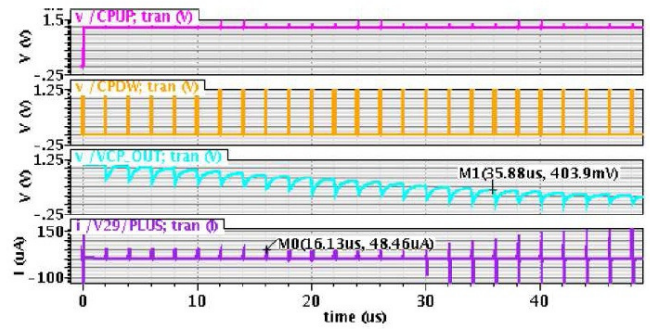

Fig. 15. Open loop simulation results of the Cadence.

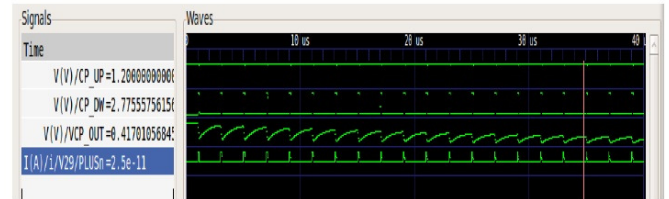

Fig. 16. Open loop simulation results of our model.

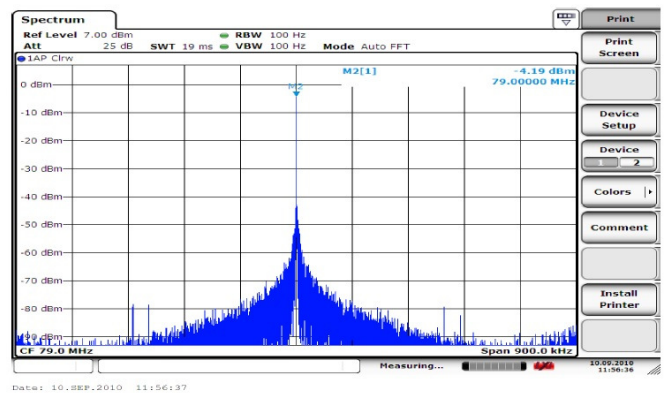

Fig. 17. Measurement result of the prescaler output PSD.

the third signal is VCO control voltage V_{tune} , the last signal is the charge pump current. As can be seen from the figure, in the 18th cycle, the value of V_{tune} of Cadence simulation results is 403.9 mV and that of SystemC/SystemC-AMS model is 417.0 mV, which are similar. The other signals are also similar, except that in the Cadence results, there are some current spurs when the current source goes into the triode region. Normally the current sources will not enter the triode region. Thus these spurs are not modelled here in order to further decrease simulation time.

D. Comparison with Measurement Results

Fig. 17 shows the measurement PSD of the Pre-Scaler output (VCO output signals divided by 30) of the PLL in [5] while Fig. 18 shows that of the SystemC/SystemC-AMS model. From these two figures, it is clear that the model can correctly reflect the real PLL noise behavior.

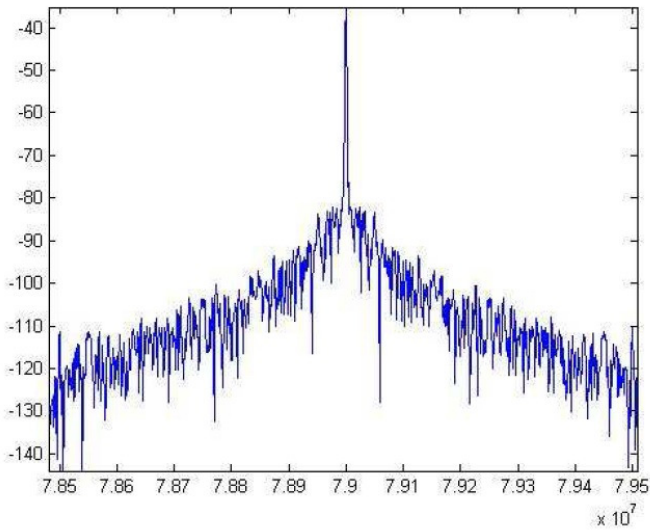

Fig. 18. Simulation result of the prescaler output PSD of our model.

VI. CONCLUSION

A new and precise mixed-signal PLL model based on SystemC/SystemC-AMS is presented in this paper. The simulation time is significantly less than that of the Matlab model. The SystemC/SystemC-AMS model gives the insights of the key characteristics determining overall system performance. Moreover, the effects of various practical imperfections are included in this model. The SystemC/SystemC-AMS model

is verified by comparing the simulation results with a Matlab model, the ADI SimPLL simulation tool and the Cadence. Also, the simulation results of the model are compared with the measurement results of a real chip implementation. These comparison results demonstrate that the model is able to precisely reflect the real system behavior with fast simulation time. They also validate that the SystemC/SystemC-AMS is an efficient and powerful language for mixed-signal modeling.

ACKNOWLEDGMENT

The authors would like to acknowledge the support from the Beyond Dreams Project.

REFERENCES

- [1] S. Huang, H. Ma, and Z. Wang, "Modeling and Simulation to the Design of $\Sigma\Delta$ Fractional-N Frequency Synthesizer," in *Design, Automation & Test in Europe Conference & Exhibition*, Nice, Apr. 2007, pp. 1–6.
- [2] L. Liu, Y. Yang, Z. Zhu, and Y. Li, "Design OF PLL System Based VERILOG-AMS Behavior Models," in *VLSI Design & Video Tech*, May 2005, pp. 67–70.
- [3] T. Xu, H. L. Arriens, R. van Leuken, and A. de Graaf, "A precise SystemC-AMS model for Charge Pump Phase Lock Loop with multi-phase outputs," in *ASICON*, Oct. 2009, pp. 1–6.
- [4] Open SystemC Initiative (10 Feb. 2010), *SystemC AMS extensions User's Guide*. [Online]. Available: <http://www.systemc.org/downloads/standards/>
- [5] P. Harpe, C. Huang, S. Rampu, and M. Vidojkovic, "Analog BAN Radio Blocks C Designs for Oct09 and April10 Tapeouts," Holst Centre, Netherlands, Tech. Rep. TN-10-WATS-TP2-050, Jun. 2010.
- [6] S. Bittner, S. Krone, and G. Fettweis, *Tutorial on Discrete Time Phase Noise Modeling for Phase Locked Loops*. [Online]. Available: <http://www.vodafone-chair.com/staff/bittner/>