

STANISŁAW WOLNY\*

**THE INFLUENCE OF OPERATING LOADS ON THE STATE OF STRESS AND STRAIN IN SELECTED LOAD-BEARING ELEMENTS OF A TOWER-TYPE HEADGEAR STRUCTURE IN THE LIGHT OF THE EXPERIMENTAL DATA****WPLYW OBCIĄŻEŃ EKSPLOATACYJNYCH NA STAN NAPRĘŻENIA ORAZ PRZEMIESZCZENIA ELEMENTÓW NOŚNYCH KONSTRUKCJI BASZTOWEJ WIEŻY SZYBOWEJ W ŚWIELE PRZEPROWADZONYCH EKSPERYMENTÓW**

In order that the ultimate state method should be applied to the strength analysis of the tower-type headgear structure, it is required that the design loads and endurance parameters be first established. For that purpose the characteristics of loads experienced by structural elements of the headgear structure are required (Wolny, 2012) as well as the numerical analysis of stresses and strains. Thus obtained results are verified through stress (strain) measurements taken in structural elements subjected to highest loads found on the basis of the stress map derived from numerical analysis, being the subject matter of the present study.

Strain (stress) measurements are taken on the beams located at the floor level +65.00 m on which the winding machines are positioned (drive shaft bearings, stators in the electric motors), as shown schematically in Fig. 2.

The strength analysis by numerical methods is restricted to those elements of the load bearing structure in the headgear at the level (+65.00) where the strain (stress) and measurements are taken and where loads are measured that give rise to the maximal strain changes (Wolny, 2012).

Alongside the strain (stress) measurements in the load-bearing elements of the headgear structure, measurements are taken of horizontal displacements at selected points of the structure with the use of an interferometric radar IBIS-S.

Results of the repeated numerical analysis of the state of stress, restricted to those elements of the load bearing structure in the tower-type headgear where the maximal loads are registered (Wolny, 2010), agree well with experimental data obtained from tests done on a real object. Therefore, the numerical analyses of the state of stress and strain in the load-bearing elements of the headgear structures operated in the Polish collieries lead us to the assumption that when analysing the geometry of the driving systems in the winding gear, the structures on which the elements of the winder installation are positioned ought to be treated as rigid. This conclusion is further corroborated by displacement measurements by geodetic methods taken on selected points of the tower-type headgear structure. An interesting point is that the tower-type headgear structure above its first floor level will behave as a rigid solid.

**Keywords:** tower – type headgear, state of stress, loading, experiment

\* AGH UNIVERSITY OF SCIENCE AND TECHNOLOGY, FACULTY OF MECHANICAL ENGINEERING AND ROBOTICS, A. MICKIEWICZA 30 AVE., 30-059 KRAKOW, POLAND

Wykorzystanie do analizy wytrzymałościowej konstrukcji wieży szybowej metody stanów granicznych wymagało określenie wielkości obliczeniowych tak obciążeń jak wytrzymałości. W tym celu niezbędnym było wyznaczenie charakterystycznych wartości obciążeń elementów konstrukcyjnych (Wolny, 2012) a ponadto przeprowadzenia analiz numerycznych w zakresie naprężeń i odkształceń. Wyniki tych analiz zostały zweryfikowane pomiarami naprężeń (odkształceń) w najbardziej wyężonych obszarach konstrukcji, wytypowanych na podstawie mapy naprężeń stanowiącej wynik analizy numerycznej, co stanowi treść opracowania.

Tensometryczne pomiary stanu odkształcenia (naprężenia) wykonano na belkach kondygnacji poziom +65,00 m na których posadowione są maszyny wyciągowe (łożyska wału napędowego, mocowania stojanów silników elektrycznych), co schematycznie pokazano na rysunku 2.

Przeprowadzono ponadto analizę wytrzymałościową (numeryczną) którą ograniczono do obszarów elementów nośnych kondygnacji (poziom + 65,00) wieży szybowej w której mierzono odkształcenia (naprężenia) oraz obciążeń, które wywoływały maksymalne wartości zmienionych wartości naprężeń (Wolny, 2012)

Równoległe z pomiarami odkształceń (naprężeń) w elementach nośnych konstrukcji wieży szybowej, wykonano pomiary poziomych przemieszczeń wybranych punktów konstrukcji, naziemnym radarem interferometrycznym IBIS-S.

Wyniki dodatkowo wykonanej (numerycznej) analizy stanu naprężenia, ograniczonej do obszarów elementów nośnych konstrukcji basztowej wieży szybowej, w których stwierdzono maksymalne wyężenie materiału konstrukcji (Wolny, 2012), w całej rozciągłości korespondują z wynikami eksperymentu przeprowadzonego na obiekcie rzeczywistym. Oznacza to, że wykonane (numeryczne) analizy stanu odkształcenia i naprężenia w elementach nośnych konstrukcji basztowych wież szybowych – aktualnie eksploatowanych w polskim górnictwie - upoważniają do przyjęcia generalnego założenia, że w ramach analizy geometrii układu napędowego maszyn wyciągowych, konstrukcje na których posadowione są elementy tego układu można traktować jako sztywne. Wniosek ten dodatkowo potwierdzają wyniki geodezyjnych pomiarów przemieszczeń, wybranych punktów konstrukcji nośnej basztowej wieży szybowej. Wyniki te – co jest pewnego rodzaju ciekawostką – wskazują że konstrukcja basztowej wieży szybowej, powyżej pierwszej kondygnacji, zachowuje się jak bryła sztywna.

**Słowa kluczowe:** basztowe wieże wyciągowe, stan naprężenia, obciążenia, eksperyment

## 1. Introduction

In order that the ultimate state method should be applied in the strength analysis of the tower-type headgear structure, it is required that the design loads and endurance parameters be first established. For that purpose the characteristics of loads experienced by structural elements of the headgear structure are required (Wolny, 2009-2012) as well as numerical analyses of stress and strains. Thus obtained results are verified through stress (strain) measurements taken in structural elements subjected to highest loads found on the basis of the stress map derived from numerical analysis, being the subject matter of the present study.

Numerical displacement data are verified by measurements of horizontal displacements of the selected points of the headgear structure during its normal duty cycle.

The repeated numerical analysis of the state of stress is performed, restricted to these load-bearing elements of the load bearing structure where the stresses (strains) are measured.

The results lead us to conclusions as to behaviour of the load-bearing elements of the tower-type headgear structure throughout the normal duty cycle of the winding installation.

## 2. Stress measurements in load-bearing elements of the headgear structure

Results of the strength analysis (state of stress) (Wolny, 2010) in load-bearing elements of the headgear structure (Fig. 1) are verified through stress (strain) measurements in structural elements subjected to highest loads.

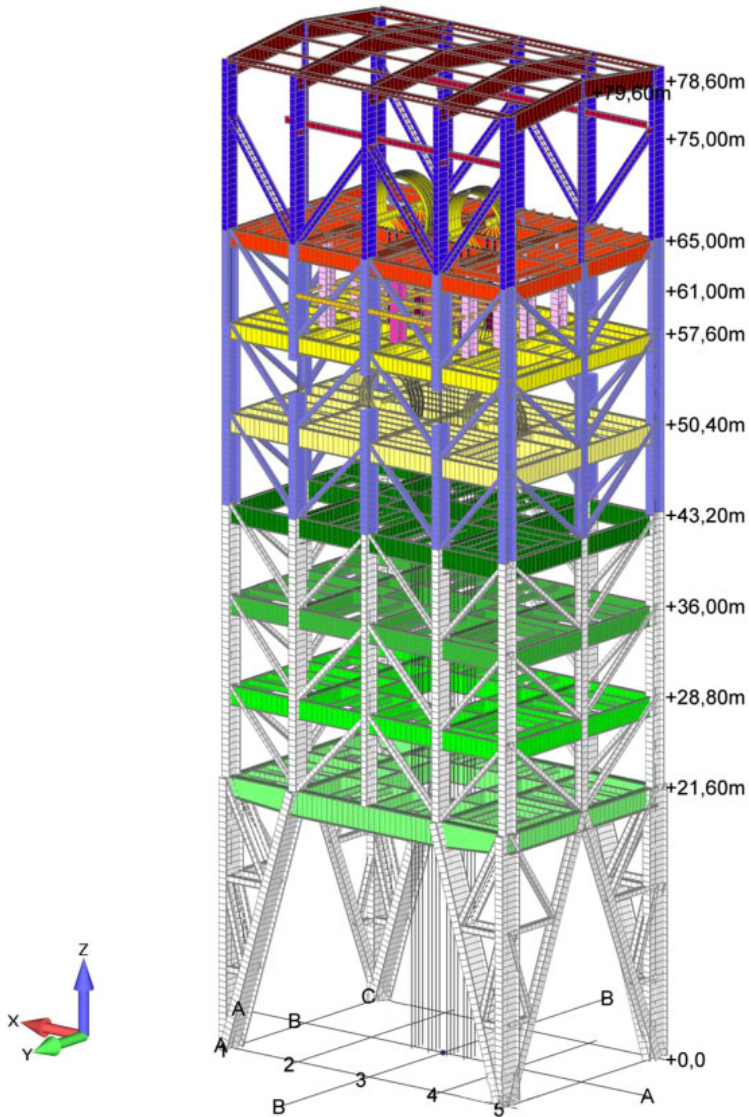

Fig. 1. Schematic diagram of the tower – type headggaer

Stresses (strains) are measured at points where the maximal loads are experienced, determined from the endurance data obtained by numerical methods (Wolny, 2012). Strain (stress) measurements are taken on the beams located at the level +65.00 m on which the winding gear is positioned (drive shaft bearings, fixing of stators in the electric motors), as shown schematically in Fig. 2.

Strain measurements are taken on six beams. Locations of the strain sensors are shown in Fig. 3. The beams at that floor level are I-section plate girders. On each beams two sensors are attached with an adhesive: one sensor to the lower flange, the other- to the web in the I-beam.

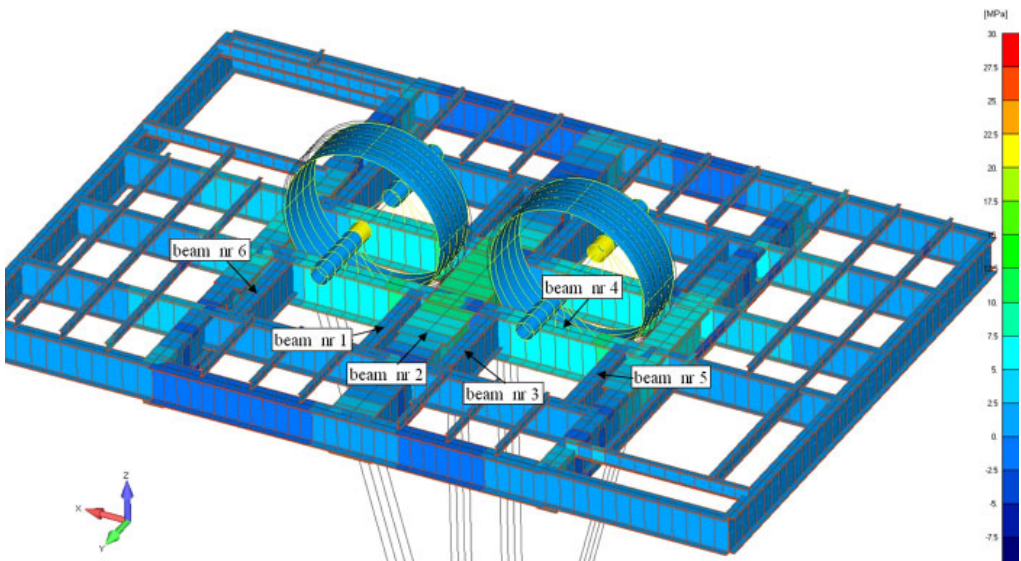

Fig. 2. Schematic diagram of the beams at the level +65.00 m

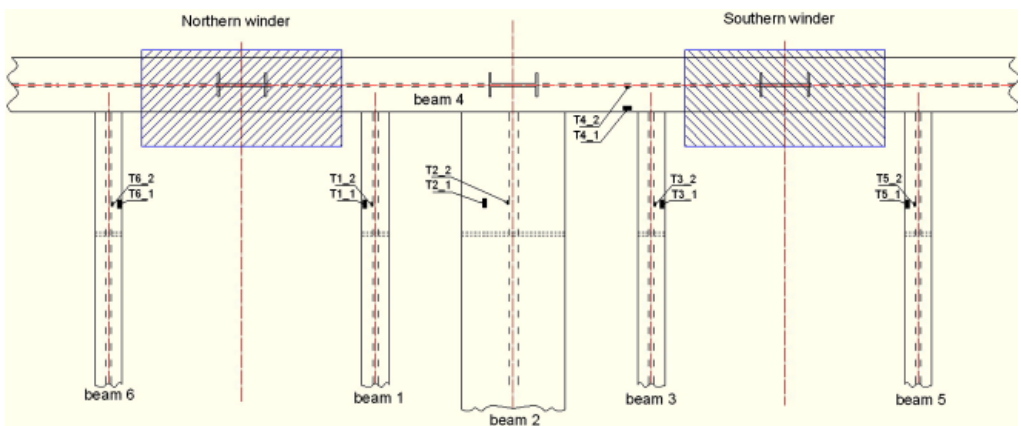

Fig. 3. Locations of strain sensors used in measurements

On beams No 3 and No 5, supporting the stator of the driving motor of the southern winder installation (Fig. 3), the strain gauges are attached in the following arrangement: T3\_ (lower flange of the beam No 3), T3\_2- web of the I-beam and T5\_1 ( lower flange of the beam No 5), T5\_2 web of the I-beam. On the beams No 1 and 6 supporting the stator of the driving motor of the northern winder (Fig. 3) the strain gauges are arranged as follows: T1\_1 (lower flange of the beam No 1), T1\_2 (the web of the beam) and T6\_1 (lower flange of the beam No 6), T6\_2 (the web of the beam). The strain sensor T1\_1 attached to the lower flange of the beam 1 is shown in Fig. 4.

The strain sensor T1\_2 attached to the web of the beam 1 is shown in Fig. 5.



Fig. 4. Strain sensor T1\_1 attached to the lower flange of the beam 1

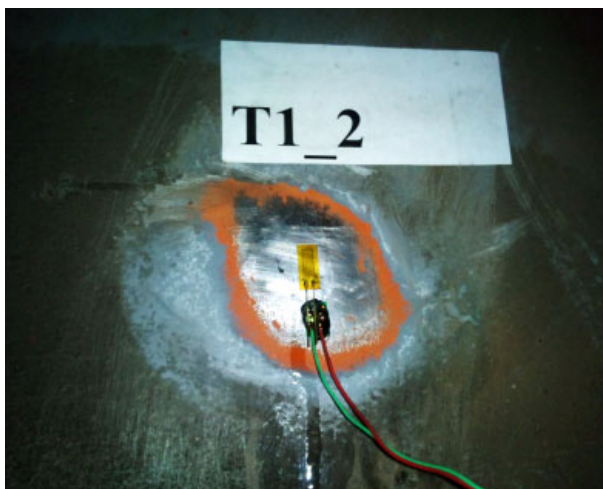

Fig. 5. Strain sensor T1\_2 attached to the web of the beam 1

Besides, strain sensors are attached to the beam No 2 diving the shaft compartments (Fig. 3): T2\_1 on the lower flange and T2\_2 on the web of the beam. Strain sensor are also provided on the beam No 4, perpendicular to the beams No 1, 2, 3, 5, 6, supporting the bearing frames of the driving shaft in the winding gear: T4\_1 on the lower flange and T4\_2 on the web of the beam.

The measurement procedure uses the following equipment:

- amplifier HBM MGC plus allowing the measurements to be taken with resistance and induction sensors,
- bridge system power-supplied from gel batteries 12V-12Ah,
- portable computer ‘laptop’ with the dedicated specialist program Catman (HBM) for online recording of measurement data.

Strain measurements are taken with strain sensors TF-5/120.

The state of strain is registered at points listed above, during subsequent stages of the duty cycle of the winder gears:

- a) operation of the northern winders only- 3 rides (the first cycle of measurements),
- b) simultaneous operation of the two winders – 3 rides (the second cycle of measurements),
- c) operation of the southern winder only- 1 ride (the third cycle of measurements),
- d) operation of the northern winder only- 1 ride (the third cycle of measurements),
- e) simultaneous operation of the two winders – 1 ride (the third cycle of measurements),
- f) emergency braking in the northern-side winding gear – (the fourth cycle of measurements).

This paper focuses on selected results of measurements only. All measurement data are summarised in the publication (Wolny et al., 2011).

Fig 6 illustrates stress variations in the beam No 1 (Fig. 2, 3) during the single duty cycle of the northern hoist, covering three full cycles of hoisting operations. Stress patterns registered by the strain sensor T1\_1 in the lower flange are plotted in red whilst stress patterns registered by the strain sensor T1\_2 in the web of the beam are plotted in blue. Stress variations registered in the beam No 1 throughout the analysed duty cycle of the winder installation do not exceed 7 MPa.

Stress variations registered on the beam No 1 during the simultaneous operation of the two winding machines throughout three full duty cycles are shown in Fig. 7. Stress patterns registered by the strain sensor T1\_2 in the lower flange are plotted in red, stress patterns registered by the strain sensor T2\_2 in the web of the beam are plotted in blue. Strain variations registered in the beam No 1 throughout the analysed duty cycle of the winding gear do not exceed 9 MPa.

### 3. Strength analysis

The strength analysis by numerical methods is restricted to these points of the load-bearing elements on the floor at level +65.00 where the stress and strain measurements are taken and where loads are experienced that give rise to maximal measured strains (the second cycle of measurements- simultaneous operation of the two winder machines). Underlying the calculation procedure is the numerical model of the tower-type headgear structure (Wolny, 2012), shown in Fig. 1. Results of the strength analysis expressed as the state of stress in lead-bearing

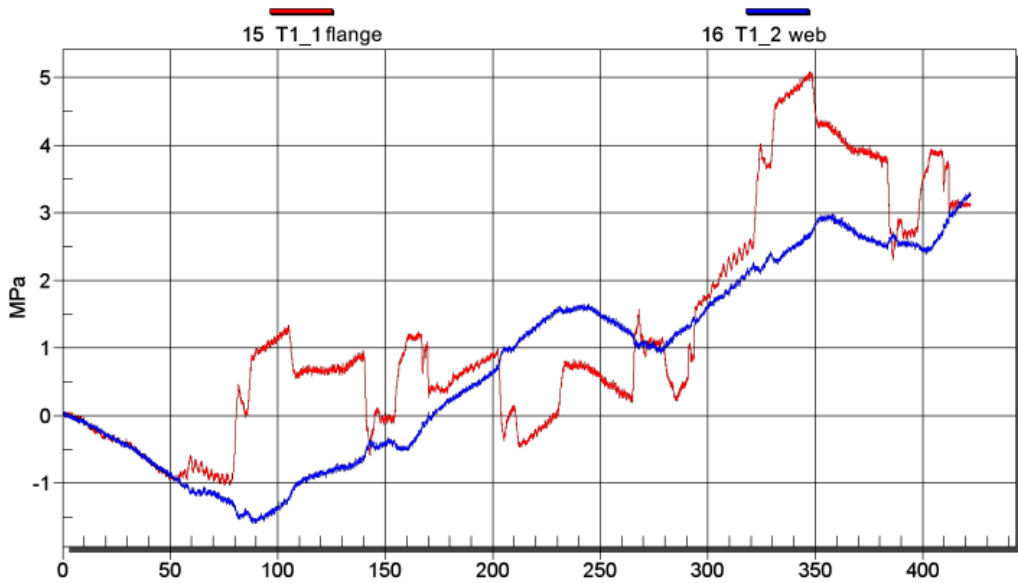

Fig. 6. Stresses registered in the beam No 1 during the operation of the northern winder only, throughout three full duty cycles

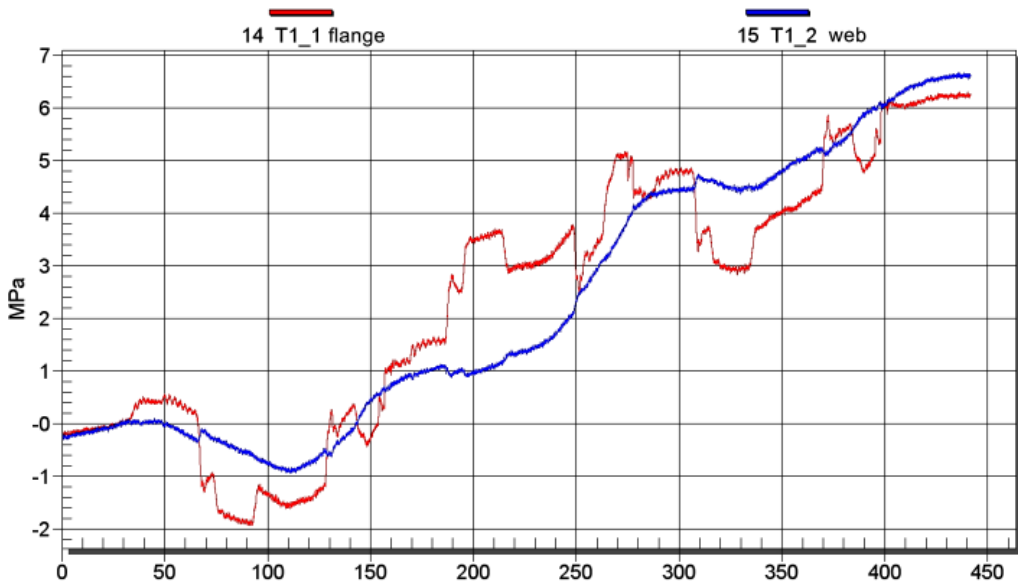

Fig. 7. Stresses registered in the beam No 1 during the simultaneous operation of the two winders throughout three full duty cycles

elements of the headgear structure are shown graphically in the work (Wolny et al., 2011). This study is restricted to presentation of the reduced stress distribution  $\sigma_z$  in load-bearing elements of headgear structure at the levels from +57.60- to 75.00 m, obtained basing on the Huber-von Mises hypothesis (Fig. 8). The largest reduced stress is registered in load-bearing roof beams +65.00, near the winding gear. In order that the state of stress in the beams at the level +65.00 should be precisely determined, this fragment of the headgear structure is shown in Fig. 9, with indicated stress contour lines. The largest values of reduced stress (about 22 MPa) are registered at connection points of beams supporting the shaft bearing and the stator. Strength analysis data reveal the maximal loads experienced by the driving element in the winder gear when the full conveyance begins to be hoisted from the bottom level, with the acceleration  $a_1$ .

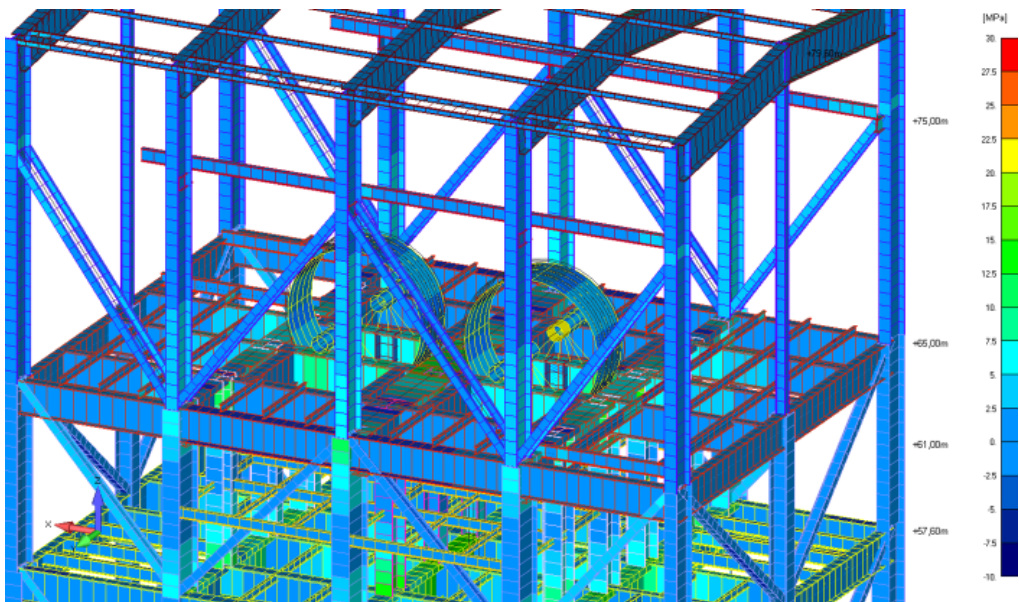

Fig. 8. Reduced stress distribution  $\sigma_z$  in load-bearing elements of the headgear structure at the levels from +57.60 m to +75.00 at the instant the full conveyance begins to be hoisted from the bottom level, with the acceleration  $a_1$

Results of numerical analysis of the state of stress in structural beams on the level +65.00 m under the minimal load acting when the full conveyance begins to brake when approaching the top level in the normal duty cycle are shown in Fig. 10. The highest levels of reduced stress under those loading conditions (around 12 MPa) are registered at joints of beams supporting the driving shaft bearing and the stator in the electric motor.

The amplitude of stress variation in the headgear elements subjected to highest operational loads fluctuates around 10 MPa and corresponds to levels of stress variations at those points measured on a real object (chapter II).



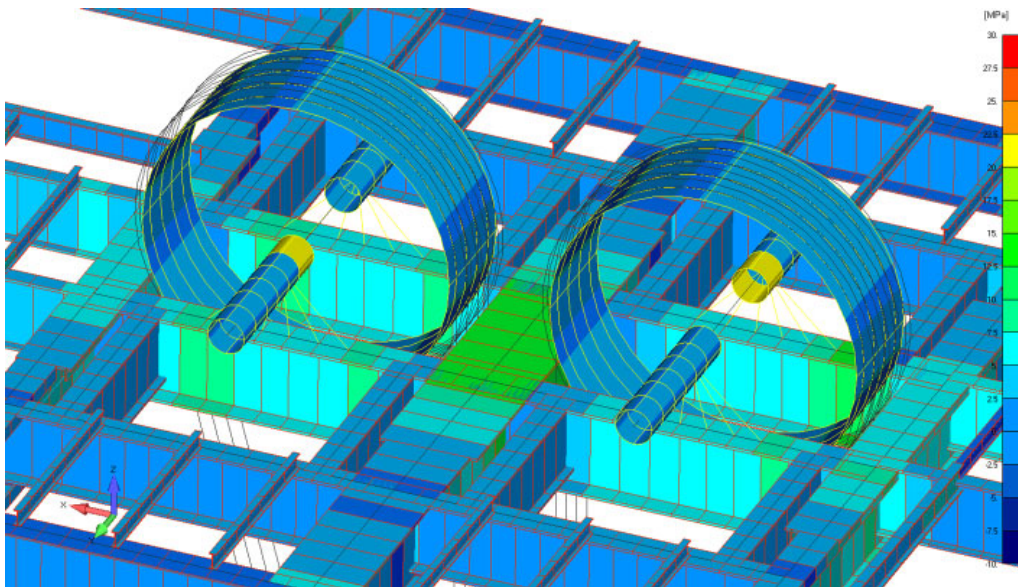

Fig. 9. Stress concentration in beams at the level +65.00 m, near the winding gear when the full conveyance begins to be hoisted from the bottom level, with the acceleration  $a_1$

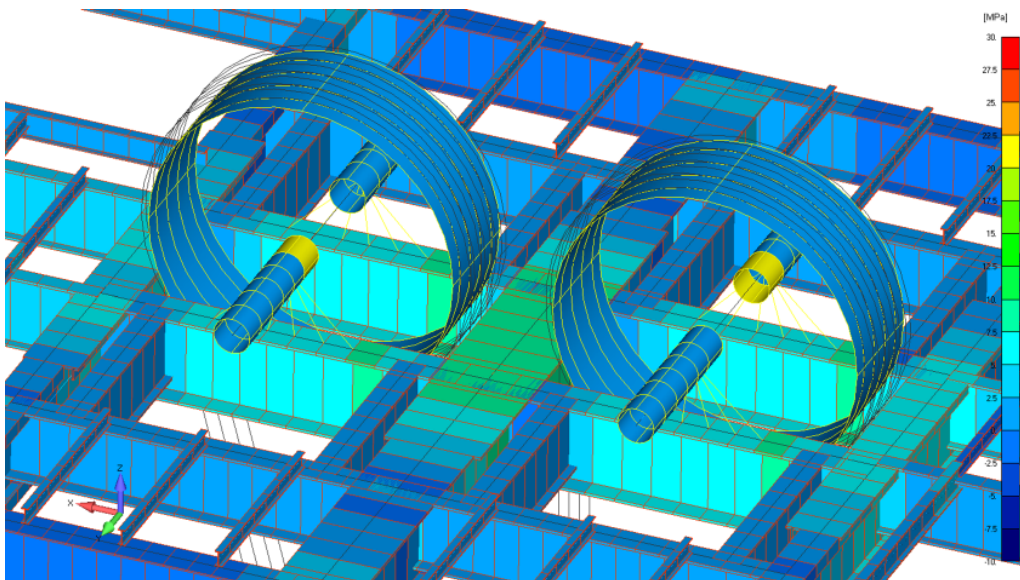

Fig. 10. Stress concentration in beams at the level +65.00 m, near the winding gear when the full conveyance begins to brake when approaching the top station

#### 4. Measurements of horizontal displacements of selected points of the headgear structure

Alongside the strain (stress) measurements in load-bearing elements of the tower –type headgear structure, horizontal displacements of selected points were registered with the use of an interferometric radar IBIS-S (Wolny et al., 2011). Measurements were taken of displacement components in two normal directions, parallel to the northern (N) and eastern (E) walls of the headgear structure (Fig. 11).

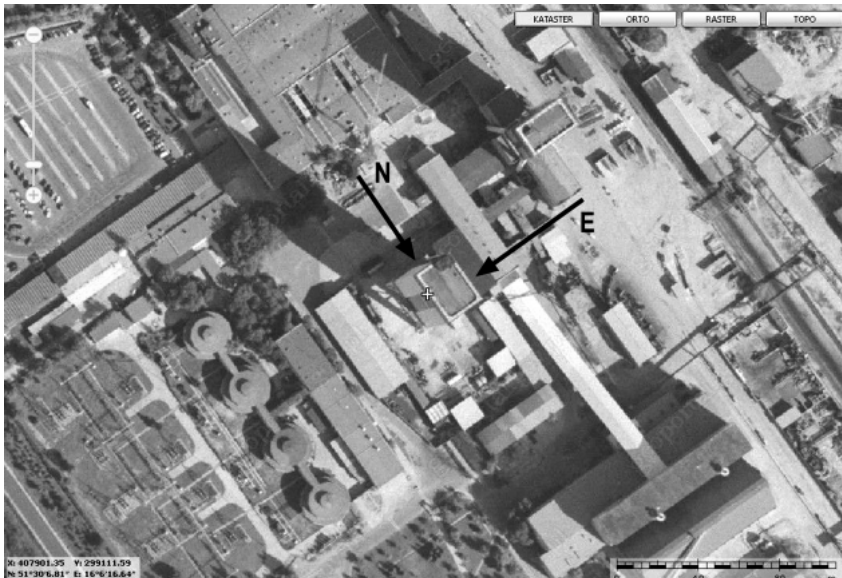

Fig. 11. Location of control points: N – northern wall, E – eastern wall

The control points were selected on the basis of radar profiling. The intensity of the radar signal reflected from the northern (N) and eastern (E) wall surface in relation to the wall height is shown in Fig. 12.

Displacements of selected control points on the northern wall throughout the duty cycle (absolute time) are shown in Fig. 13.

Displacements of selected control points (as before) in the first cycle of measurements (operation of the northern winder only – 3 rides) are shown in Fig. 14.

Measurements taken during the normal operation of the winder installations installed in the tower-type headgear structure reveal that the maximal amplitude of horizontal displacements fluctuates around 1 mm. During the emergency braking operations, this amplitude would be slightly higher, approaching  $\pm 1.5$  mm (Wolny et al., 2011).

It is worthwhile to mention that under the normal operating conditions, the tower-type headgear structure above its first floor level (+20.11 m) will behave as a rigid solid.

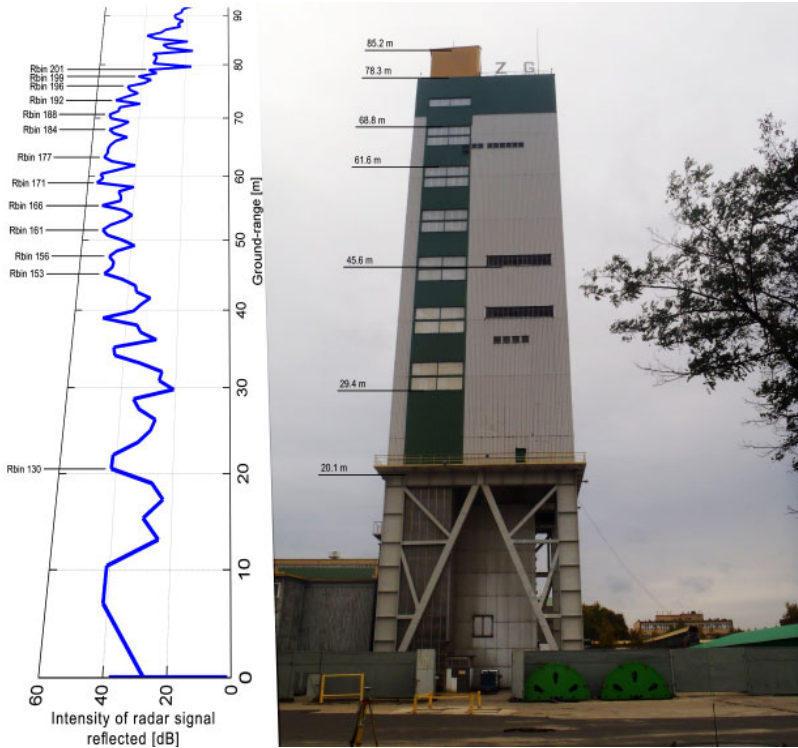

Fig. 12. Radar profile and the view of the northern wall (N)

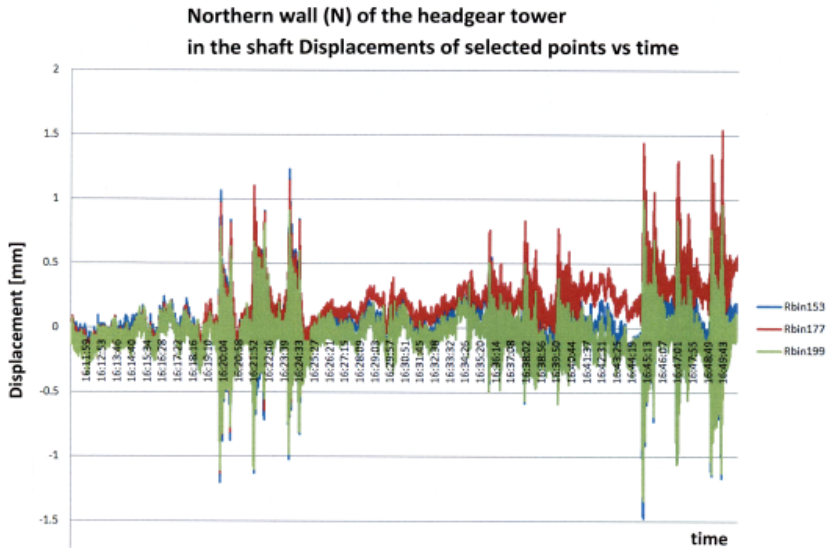

Fig. 13. Displacements of selected control points of the headgear tower in the function of time – northern wall

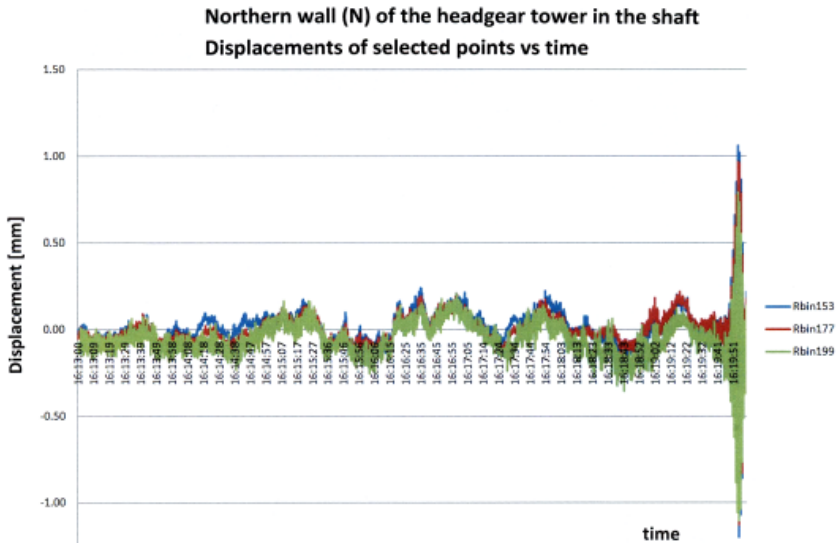

Fig. 14. Displacements of selected points of the headgear tower in the shaft RII Rudna between 16.13 and 16.20 – northern wall

## 5. Conclusions

Results of strain and stress analysis carried out by numerical method and restricted to those elements of the load-bearing structure of the currently operated tower-type headgear structures which have to withstand the maximal loads (Wolny, 2012) agree well with experimental data collected from tests on a real object. It is reasonable to assume, therefore, that when analysing the geometry of the driving systems in the winder gears, the structures on which the elements of the winder installation are positioned ought to be treated as rigid. This conclusion is further corroborated by displacement measurements taken at selected points of the tower-type headgear structure by geodetic methods. It is worthwhile to notice that the tower-type headgear structure above its first floor level will behave as a rigid solid.

## References

- Wolny S., 2009. *Dynamic loading of the pulley block in a hoisting installation in normal operating conditions*. Archive of Mining Sciences, Kraków, Vol 54, No 2, p. 261-284.
- Wolny S. et al., 2011. *Opracowanie metody kontroli fundamentów maszyn wyciągowych zainstalowanych na wieżach basz-towych*. Praca naukowo-badawcza. Katedra Wytrzymałości Zmęczenia Materiałów i Konstrukcji. AGH, Kraków.
- Wolny S., 2011. *Dynamic loading of Conveyances in Normal Operating Conditions*. Archive of Mining Sciences. Vol. 56. No 4, p. 665-682.
- Wolny S., 2012. *The influence of operating loads on the state of stress and strain in select load – bearing elements of a tower – type headgear structure*. Archive of Mining Sciences, Vol. 57, No 3, p. 497-515.