

IVANA JOVANOVIĆ*, IGOR MILJANOVIĆ**

MODELLING OF FLOTATION PROCESSES BY CLASSICAL MATHEMATICAL METHODS – A REVIEW**MODELOWANIE PROCESU FLOTACJI PRZY POMOCY KLASYCZNYCH METOD MATEMATYCZNYCH – PRZEGLĄD**

Flotation process modelling is not a simple task, mostly because of the process complexity, i.e. the presence of a large number of variables that (to a lesser or a greater extent) affect the final outcome of the mineral particles separation based on the differences in their surface properties. The attempts toward the development of the quantitative predictive model that would fully describe the operation of an industrial flotation plant started in the middle of past century and it lasts to this day.

This paper gives a review of published research activities directed toward the development of flotation models based on the classical mathematical rules. The description and systematization of classical flotation models were performed according to the available references, with emphasize exclusively given to the flotation process modelling, regardless of the model application in a certain control system. In accordance with the contemporary considerations, models were classified as the empirical, probabilistic, kinetic and population balance types. Each model type is presented through the aspects of flotation modelling at the macro and micro process levels.

Keywords: flotation, mathematical modelling, empirical models, probabilistic models, population-balance models, kinetic models

Modelowanie procesów flotacji nie jest zagadnieniem prostym, głównie z uwagi na skomplikowany charakter samego procesu, czyli znaczną liczbę zmiennych które, w mniejszym lub w większym stopniu, mają wpływ na końcowy wynik procesu separacji cząstek materiału wykorzystującego różnice w ich właściwościach powierzchniowych. Próby stworzenia ilościowego modelu predyktywnego który w sposób pełny opisywałby przemysłowe procesy flotacji podjęto w połowie ubiegłego wieku a badania trwają po dzień dzisiejszy.

W artykule przedstawiono przegląd działalności badawczej podejmowanej w celu opracowania modelu procesu flotacji opartego o zasady matematyki klasycznej. Opisu i systematyki modeli flotacji dokonano

* MINING AND METALLURGY INSTITUTE BOR, MINERAL PROCESSING DEPARTMENT, ZELENI BULEVAR 35, 19210 BOR, SERBIA. E-mail: ivajo7@gmail.com

** UNIVERSITY OF BELGRADE, FACULTY OF MINING AND GEOLOGY, DEPARTMENT OF APPLIED COMPUTING AND SYSTEM ENGINEERING, DJUSINA 7, 11000 BELGRADE, SERBIA. E-mail: imiljan@rgf.bg.ac.rs

w oparciu o dostępną literaturę przedmiotu, główny nacisk kładąc na te modele, które wykorzystywane były wyłącznie do analizy procesu flotacji, bez względu na możliwość ich zastosowania także w układach sterowania. Zgodnie z obecnymi założeniami, modele sklasyfikowano jako empiryczne, probabilistyczne, kinetyczne oraz modele równowagi populacji. Każdy model zaprezentowany jest w kontekście modelowania procesu flotacji, z uwzględnieniem skali mikro oraz makro.

Słowa kluczowe: flotacja, modelowanie matematyczne, modele empiryczne, modele probabilistyczne, modele równowagi populacji, modele kinetyczne

1. Introduction

The underlying principles of the flotation process are well established, but, according to the reports from many researchers, it is very hard to create the quantitative predictive models that can be used to simulate the operation of flotation cells in typical industrial circuits. The reason for these difficulties lies in the complexity of the many microprocesses and their mutual interactions influencing overall result, which is the separation of different mineral species by virtue of the differential surface conditions that can be induced on the various minerals (King, 2001).

Since the thirties, numerous mathematical models were presented which, with higher or lower adequacy, describe the flotation process. Historically, primarily the classical flotation models were developed (Garcia Zuñiga, 1935; Schumann, (1942; Kelsall, 1961; Woodburn, 1970; Harris, 1978; Lynch et al., 1981; Zhang, 1989; Yianatos, 1989; Schulze, 1993; Polat & Chander, 2000; King, 2001; Sherrell, 2004; Ali, 2007; Yianatos, 2007; Saleh, 2010; Xian-ping et al., 2011; etc.). With the development and application of computer techniques in flotation process modelling, in parallel with the classical models, development of soft computing based models started (Moolman et al., 1994; Çilek, 2002; Vieira et al., 2005; Marais & Aldrich, 2011; Nakhaei et al., 2012; Nakhaei et al., 2013; etc.).

Hitherto, the approach to the construction of mathematical models of flotation varied due to the scientific standpoint of an expert, expected model application and the available investments regarding human resources and time. Published models differ from types based on fundamental mathematical equations to the empirical types. Their potential use is not related only to the process simulation but to the process analysis as well.

For example, models can be used for data analysis that, from the perspective of technological process complexity, is not easy to achieve: such as the desired metal recovery in fine and coarse particle size classes of final and intermediary products and the prevention of the unwanted metal recovery in the fine classes of the concentrate. Furthermore, models can be used as a tool for improving the understanding of flotation process prior to operation of an automatic control system (Lynch et al., 1981).

Polat and Chander (2000) state that the micro- and macro-scale models are often used for flotation process description. In the micro-scale models, the sub-processes of the flotation system are identified and used to determine the cause and effect relationships between the system variables. In macro-scale modelling, the overall response of the flotation system is related to various operating parameters through a set of mathematical equations or rules and expressions of soft computing.

Flotation models can be generally divided into two categories: *empirical* and *phenomenological models* (Polat & Chander, 2000; Casali et al., 2002; Rojas & Cipriano, 2011). Phenomenologi-

cal models can be further classified as *probabilistic*, *kinetic* and *population-balance* types (Polat & Chander, 2000), but it should be noted that setting the clear boundaries in classification is often not possible. For example, the population-balance models can be viewed as the separate type of kinetic models, where the principles based on the probability of certain flotation subprocesses occurrence are often used.

Beside the basic classification, Hodouin (2011) states that models differ according to whether they are:

- Steady-state or Dynamic;
- Deterministic or Stochastic;
- Causal (input-output model) or non-causal (a set of relationships linking process variables, such as weight conservation constraints);
- Linear or non-linear;
- Based on mathematical equations or fuzzy rules.

Since the many disturbance variables exist in flotation system, it is not possible to create a model from a completely theoretical analysis, and even if it were possible, the model would be very impractical, due to its complexity. Therefore, no purely theoretical flotation model was developed to this day (Zhang, 1989).

The selection of model type depends on the real process conditions and the desired performances. However, it should be stated that models of complex process such as flotation, cannot fully represent the real process. Therefore, it is necessary to recognize the weaknesses of each model and, depending on the expected application, to disregard exactly those technological aspects of the process having the minimal influence to the model adequacy.

2. Flotation variables

According to the literature data, there is an estimation of approximately 100 variables that affect (to a different extent) the flotation process (Laurila et al., 2002; Harris et al., 2002), making it very complex real time process. Apart from that, the mutual interactions between variables further complicate control efforts. For example, an increase in air flowrate may well result in a larger air bubble size, which will subsequently affect the bubble rise velocity, rate of attachment, gas holdup, froth depth, etc. (Ćalić, 1990; Milošević, 1994; Shean & Cilliers, 2011).

Furthermore, in industrial conditions, change of any variable at any bank in a flotation circuit causes a change of pulp composition and flowrate of each stream leaving that bank, as well as the changes in all later and even earlier streams (if there is a recirculation stream going back to an earlier stage) of the circuit. Lynch et al. (1981) give an example for the concentration of sulphide lead and zinc ores where the increase in pulp level of the scavenger bank results in higher initial recoveries of valuable minerals, gangue and water in scavenger concentrate. The increased material quantity from the scavenger concentrate affects the increase of pulp flowrate in the rougher stage of flotation, with decreased retention time in the rougher bank cells. Changes occurring in cleaner stage as well as the final result of the plant operation will reflect in increased recovery of the valuable component, but also in lower grade of the concentrate.

It should be noted that the interacting effects of changes in more than one variable within a short time can reflect on the disturbances in flotation plant operation for a longer period of time.

Hodouin (2011) defines the status and the features of key input and output variables influencing the flotation process. In addition, the same author classifies input variables to:

- (1) Manipulated (i.e. variables that can be influenced) and
- (2) Disturbance variables,

while the output variables are classified as:

- (1) Controlled (i.e. variables describing process performances) and
- (2) Internal state variables (dependent on manipulated and disturbance variables)

Similarly, Miljanović (2008) presents graphically the definition and classification of key flotation variables. The modified schematic representation is given in Figure 1.

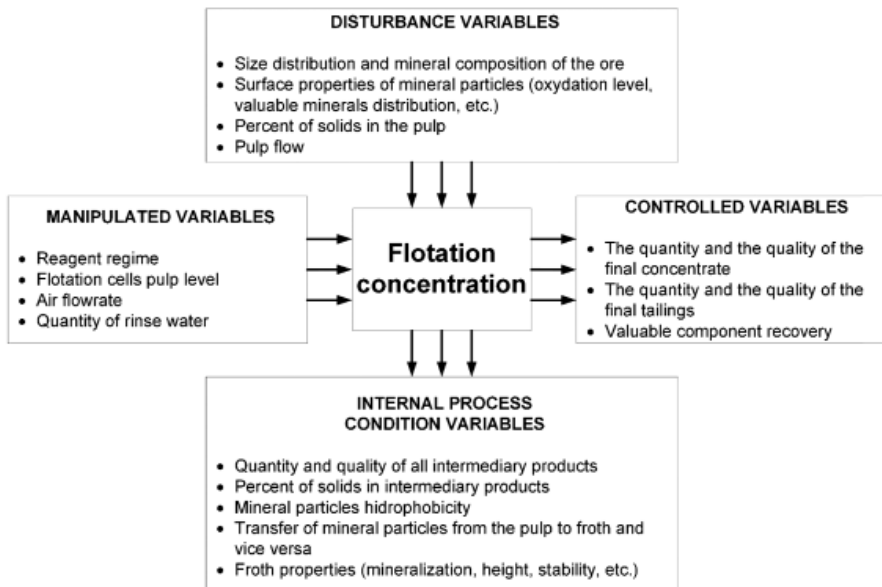

Fig. 1. Process variables in flotation plant (adapted from Hodouin, 2011; Miljanović, 2008b)

The influence of the diverse variables on the course and results of flotation process is the research topic for many authors (Lynch et al., 1981; Yianatos, 1989; Zhang, 1989; King, 2001; Vera, 2002; Drzymała, 2007; Uçurum & Bayat, 2007; Villar et al., 2010; Shammas et al., 2010; Maldonado, 2010; Rahman, 2012; Rath, 2013). A conclusion can be drawn from these extensive researches, is that the influence of flotation variables in varying degrees and their interactions on the one hand, and distinct tendency for achieving the process stability and products quality on the other hand are conflicted in the domain of process control and achieving the desired performances with the simultaneous maintenance of all disturbances under control.

The problem of achieving the optimal operational regime of the flotation plant with the numerous variables is difficult even when the flotation properties of the ore entering the process changes only slightly. In case of intense and frequent changes in ore flotation properties (which is almost always occur in industry), the problem becomes even more complex. Therefore, the selection of simulation techniques is helpful for the process of resolving this issue (Lynch et al., 1981).

3. Modelling of flotation processes by classical methods

Concept of classical modelling the flotation process is based on the standard mathematical rules and expressions describing the behaviour of the flotation system.

3.1. Empirical models

Regarding to classical empirical models (i.e. models based on the experience data) a correlation between the quantities of floated material and the input and output variables is established through appropriate mathematical equations. Statistical methods are used to determine the connection between the dependent and independent variables, as well as for the estimation of parameters relevant in approximation of the appropriate functional dependences. Parameters obtained by such analysis usually don't have physical significance (Polat & Chander, 2000).

Lynch et al. (1981) consider empirical models suitable for the description of flotation banks or entire plants. Data collecting for empirical models can be performed by on-line and off-line methods. In off-line methods, the data can be collected from regular shift or daily operating data- or data obtained by particular process of sampling according to the defined experimental program. In on-line methods, collection of data is performed exclusively on-line by means of instrumentation technique, although the analysis of data can be performed off-line as well. Process equipment that continually provides basic data for the development of empirical models and for their later updating is usually installed at the input or output stream of the flotation bank or plant.

Possibility of the application of empirical flotation models was described already in the middle of the XX century by Faulkner (1966) and Pitt (1968).

Lately, several empirical models for the copper recovery and grade optimization in copper ore concentrate from North Waziristan (with chalcopyrite as the main copper-bearing mineral) were developed by Ali (2007). Examples of classical empirical models describing certain subprocesses in the flotation system (mainly microprocesses occurring at the contact of pulp and froth phase) are given by Savassi et al. (1998), Gorain et al. (1999), Tsatouhas et al. (2006) and Yianatos and Contreras (2010).

Empirical models are often combined with phenomenological, in order to make the simulation process model as efficient as possible (Kuopanportti et al., 2000; Casali et al., 2002; Bakker et al., 2010).

The main advantage of empirical models is that their application often requires lower costs than other model types regarding human resources and time. If the expected model application is clearly defined, they can be used in engineering practice in a satisfactory manner. However, predictions outside of the model database boundary should be carefully considered. Furthermore, models can significantly differ for various ores and various types of flotation plant design, therefore, it is very difficult to determine the relation between the published empirical models.

Hence, the application of empirical flotation models improves the understanding of technological parameters for a specific ore, i.e. the specific flotation plant (Lynch et al., 1981).

3.2. Probabilistic models

Probabilistic models are based on the possibility of occurrence of different subprocesses such as collision, adhesion and detachment of particles and air bubbles. They can serve as a tool

for the description of flotation process at the macro or micro level, or otherwise represent a connection between these two types of models (Polat & Chander, 2000).

Considering the particle size, cell volume and froth stability, Schumann (1942) suggested a probabilistic flotation model presented by the equation (1):

$$P_x = P_c \cdot P_a \cdot F \cdot [x] \cdot V \quad (1)$$

where:

- P_x — Probability of the successful transfer of a particle to the concentrate;
- P_c — Probability of the particle-air bubble collision;
- P_a — Probability of the particle-air bubble adhesion;
- F — Froth stability factor;
- $[x]$ — Average particle size;
- V — Flotation cell volume.

Since the various probabilities and independent factors are unknown in the overall process, and there is no efficient method to measure the individual probability and the effect of the factors, this model is not practical. After the probabilistic model given by Schumann (1942), Kelsall (1961) developed the alternative approach to the model enabling the easier measurements. He had considered that the weight of a certain component in the tailings obtained by flotation in the isolated flotation cell (during the stable state of process) is proportional to the weight of the same component in the feed. The model is represented by the equation (2):

$$W = W_0 \cdot (1 - P)^n \quad (2)$$

where:

- W — Weight of the component in the tailings;
- W_0 — Weight of the component in the feed;
- P — Probability of the component transfer into the concentrate;
- n — Factor describing the process efficiency.

Model (equation (2)) is simple for use, but it should be stated that in this case, flotation concentration is considered as the discontinuous process and the time is not taken into account. However, from the probability point of view, value of the parameter P is the highest at the beginning of the flotation process, because floatable particles have intense tendency to be transferred to the concentrate. As the process continues, this probability gradually decrease, meaning that P should be viewed as a time function. By differentiating the equation (2) with respect to P , and introducing the functional dependence $P(t)$ with the appropriate mathematical transformations, the general first order kinetics model is obtained. This model (equation (3)) is often used in describing the flotation processes (Zhang, 1989):

$$\frac{dW}{dt} = -k(t) \cdot W \quad (3)$$

In this case, the flotation rate constant k is calculated from the appropriate probabilities.

Examples of such model are given by Schulze (1993), as well as Schulze and Stöckelhuber (2005). For the purpose of the calculation of flotation rate constants, these authors have taken into

account concentration of air bubbles available for adhesion to mineral particles, the frequency of the particle-bubble collision, as well as the appropriate probabilities of: collision, adhesion, three-phase contact formation and stability of particle-bubble aggregates against external stress forces. By using the same general principles expressed by Schulze (1993), Bloom and Heindel (1997) have presented kinetic constants as the functions of the probability of the occurrence of different microprocesses in the flotation system and developed a complex model to describe flotation of toner particles from the recycled paper. Koh and Schwarz (2006) have also applied the probabilistic approach in describing the flotation microprocesses within the development of kinetic model for the particle adhesion to air bubbles in flotation pulp.

Apart from the earlier mentioned probabilistic models describing the flotation process at the macro level, and those representing the linking segments within the complex kinetic models, research publications also contain probabilistic models that independently describe microprocesses of the flotation process (Kirjavainen, 1989; Nguyen et al., 1998; Nguyen, 1998; Brožek et al., 2012).

3.3. Kinetic models

Kinetic modelling of flotation processes is based on the assumptions that the rate of the particle-bubble collision process is first-order, while number of particles and the air bubble concentration remains constant [Polat & Chander, 2000]. Regardless of the numerous scientific discussion about the actual order of the flotation process kinetics (for example: Somasundaran and Lin (1973) suggested graphical methods offering “relatively simple and fast way for the evaluation of the order and the rate constant of a flotation operation”; Brožek and Młynarczykowska (2007) are stating that flotation process kinetics order is varying with time; Li et al. (2013) assert that during the coal flotation, organic component floats according to the first-order kinetics, while the inorganic component floats according to the second-order kinetics; while Hernáinz and Calero (1996, 2001) in testing the flotation process kinetics of the celestite and calcite reached the conclusion that the order of flotation kinetics is not an integer value), the most widely accepted approach among the researches is still the first-order kinetics (Fichera & Chudacek, 1992; Polat & Chander, 2000; Sripriya et al., 2003; Natarajan & Nirdosh, 2006; Oproiu et al., 2009; Yianatos et al., 2010). That means the flotation cells can be modelled according to the analogy with chemical reactors with perfect mixing (Yianatos et al., 2005a; Yianatos & Henríquez, 2006; Yianatos, 2007), while the transfer of mineral particles from the pulp phase is defined by the first-order reaction rate equations (Polat & Chander, 2000).

Solution of the first-order rate equation results in the classical first-order flotation model. Classical first-order equation must be modified to represent the data of flotation rate under a wide range of conditions, while the general principle of kinetic models is brought down to the determination of the flotation rate constant, k (Polat & Chander, 2000; King, 2001).

The flotation rate constant depends on many factors, such as: air flowrate, mineral particles size, air bubble size, pulp density and level, reagent concentration, flotation cell design, etc. (Hernáinz & Calero, 2001; King, 2001; Runge et al., 2003a; Duan et al., 2003; Sherrell, 2004; Uçurum & Bayat, 2007; Mohammed, 2007). Therefore, it is very difficult, or virtually impossible to precisely determine the value of constant k .

Ferreira and Loveday (2000) state that kinetic models of the discontinuous flotation processes can be divided into two basic groups, according to distribution of the first-order rate constants.

Those are discrete and continuous models. Discrete models can be presented by a general (modified) equation (4):

$$\frac{R}{R_{max}} = \sum_{i=1}^n \varphi_i \cdot (1 - e^{-k_i t}) \quad (4)$$

where:

- R — Cumulative recovery of a component at time t ;
- R_{max} — Maximum possible recovery of a component;
- n — Number of floatable classes;
- φ_i — Mass ratio of the floatable fraction i expressed in decimals;
- k_i — First order rate constant of particles in floatable class i ;
- t — Flotation time.

One of the first discrete kinetic models was presented by Kelsall (1961). Proposed model is based on the floatability of two fractions in the pulp (the slow-floating and fast-floating fraction). Behaviour of each fraction is described by individual rate constants. By an analogy to this model, Zhang (1989) represented the model with three floatable fractions, including the medium-floating fraction with the appropriate rate constant. Hay (2008) published the advanced model for the optimization of nickel flotation process based on the Kelsall's model, while Welsby et al. (2010) have suggested the method for classification of floatable fractions from the lead-zinc ore (wherein they gave their mass contents and the appropriate flotation constant rates) based on the mineral particles size and the liberation degree of galena, and highlighted its significance in developing the Kelsall's and the similar models. The development of discrete flotation models was also a research topic for Runge et al. (2003b), Dehghani et al. (2011) and Saleh (2010).

Models with continuous distribution of the flotation rate constant describing the discontinuous flotation process can be presented by a general equation (5) (Yianatos et al., 2010):

$$\frac{R}{R_{\infty}} = \int_0^{\infty} (1 - e^{-kt}) F(k) dk \quad (5)$$

where:

- R — Recovery of the component at time t
- R_{∞} — Maximum recovery of the component at infinite time
- k — Kinetic rate constant which involves all the microscopic subprocesses
- $F(k)$ — Rate constant distribution function for mineral species with different flotation rates

The expression $(1 - e^{-kt})$ represents the mineral recovery of a first-order process with invariant rate constant k , as a time function.

Different investigators propose different distribution functions for k . Certain of them are the gamma distribution (Saleh, 2010; Yianatos et al., 2010), the rectangular distribution (Runge et al., 2003b; Yianatos et al., 2005b, 2006, 2010; Yianatos & Henríquez, 2006; Xian-ping et al., 2011; Saleh, 2010), the Weibull distribution (Yianatos et al., 2010), double normal distribution (Ferreira & Loveday, 2000). Additionally, Polat and Chander (2000) in their extensive presentation of the first-order kinetic models involve the possibility of utilization of the triangular and sinusoidal distribution of the flotation process rate constant. Testing the compatibility of various distribution functions to represent the flotation rate constant in modelling of copper flotation

process, Yianatos et al. (2010) included, among others, the Dirac delta function, which is essentially brought down to discrete model with one floatable fraction. Kalinowski et al., stated that the most commonly accepted mathematical models of the flotation kinetics are: the model of multi-fractional and fractional one, and the model of gamma floatability distribution. At the same time, the authors suggest triangular distribution for density function of coal particles floatability (Kalinowski et al., 2013).

Nevertheless, in spite of many attempts to determine constant k as accurately as possible, and consequently to define the most adequate flotation process model as possible, the generally accepted opinion is that there is no unique model describing flotation kinetics well enough.

For continuous flotation processes, mineral recovery can be generally presented by equation (6) (Yianatos et al., 2007; Yianatos, 2012):

$$\frac{R}{R_{\infty}} = \int_0^{\infty} \int_0^{\infty} (1 - e^{-kt}) F(k) E(t) dk dt \quad (6)$$

where: $E(t)$ — residence time distribution function for continuous processes with different mixing characteristics.

The rest of the parameters have the same meaning as in equation (5).

Residence time distribution function $E(t)$ depends on the hydrodynamic regime and is related to cell design and circuit arrangement. Yianatos (2007) proposed a relatively simple model for determining the function $E(t)$ for the high volume (130 m³) single flotation cell. The model showed good compliance with the experimental data obtained by testing the liquid and three solid fractions (fine, medium and coarse). The same author also defined models for determining $E(t)$ for flotation bank containing N cells and flotation column.

3.4. Population-balance models

Population-balance models are special type of discrete kinetic models. The population-balance approach originate from an idea that mineral particles in the cell are conceptually divided into groups, where the particles in any one group are similar in dimensions and mineral composition (King, 2001). General principles of flotation process population-balance modelling are described by Herbst and Harris (2007). According to this model, concentration of mineral particles in the flotation cell is considered for each group defined, depending on the particle state in the cell (i.e. free in the pulp, attached to the air bubble in the pulp, free in the froth or attached to the air bubble in the froth, as presented in Figure 2). Mathematically, it can be generally presented by a set of differential equations (7) (adapted according to Herbst and Harris (2007), and Herbst and Flintoff (2012)):

$$\frac{\partial V \psi_j}{\partial t} = \psi_{jIN} Q_{IN} - \psi_{jOUT} Q_{OUT} + \sum_{i=1}^n k_{ji} \psi_i V \quad (7)$$

where:

- ψ_j — Concentration of mineral particles in each of the four possible states (every object state is defined by a single differential equation);
- V — Volume of flotation cell;

- Q_{IN} — Volumetric flowrate of the input material (water or air) in the pulp phase or the froth phase (see Fig. 2);
- Q_{OUT} — Volumetric flowrate of the output material (water or air) from the pulp or froth phase (see Fig. 2);
- ψ_{jIN} — Concentration of mineral particles in one of four states that will, due to certain mechanisms, pass into the object state, or they are already in the object state;
- ψ_{jOUT} — Concentration of mineral particles in one of four states that are not in the object state, or they will, due to certain mechanisms, leave object state;
- k_{ji} — Transfer rate between the states according to any of the mechanisms (i.e. attachment or detachment of the particle and the air bubble, entrainment of particles into froth or their drainage from the froth, etc.);
- j — correspond to the mineral particle size;
- i — correspond to the mineral particle composition.

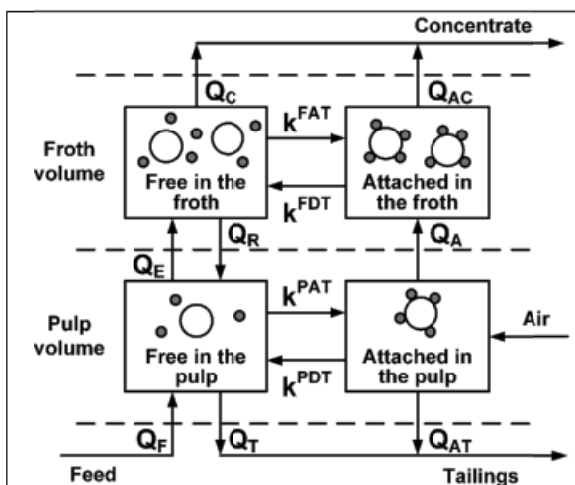

Fig. 2. Four-state population balance model for particles in a flotation cell [Herbst and Harris (2007)] (Q_F, Q_C, Q_T – water flowrate in the feed, concentrate and tailings, respectively; Q_A, Q_{AC}, Q_{AT} – air flowrate in the feed, concentrate and tailings, respectively (in practice, $Q_{AT} \approx 0$); Q_R – flowrate of water returning from froth to pulp, Q_E – flowrate of water transferred from pulp to froth; k^{PAT}, k^{PDT} – transfer rate of attachment and detachment of particles and air bubbles in pulp, respectively; k^{FAT}, k^{FDT} – transfer rate of attachment and detachment of particles and air bubbles in froth, respectively)

Upon establishing the set of differential equations, transfer rate constants are determined, based on mathematical equations and experimental data.

Pérez-Correa et al. (1998) presented a model describing the dynamics of flotation plant, based on the mass balances with first order flotation kinetics. The key model assumptions are:

- Existence of two phases in the flotation cell (the pulp and the froth);
- Existence of two mineralogical classes: rich minerals (useful minerals, mostly chalcocopyrite) and poor minerals (mostly gangue);
- Each phase in the cell is perfectly mixed;

- d) Material transfer between phases occurs in both directions;
- e) Pulp and froth densities are constant;
- f) Only one particle size affects the flotation rate (although this can vary);
- g) Cell lines are considered as a supercell with equivalent total volume.

Model variables are classified as follows:

- Input variables
 - manipulated: collector doses, frother addition rate, pulp level;
 - disturbances: copper feed grade, feed flowrate, average feed particle size, iron feed content and the pH of the feedstream.
- Output variables
 - measured: copper concentrate grade, copper tailing grade, recovery
 - non-measured: concentrate and tailing flowrates (Pérez-Correa et al., 1998).

The population-balance approach in flotation process macro-scale modelling was applied also by Bloom and Heindel (1997), Sosa-Blanco et al. (1999), Casali et al. (2002) and Sbarbaro et al. (2008).

Modelling of subprocesses in the flotation system by population-balance approach is, according to the available literature data, mostly reduced to predicting the distribution of air bubbles in the system (Deglon et al., 1999; Sawyerr et al., 1998; Koh & Schwarz, 2008).

Finally, it should be stated that the given classification of classical flotation models is not strict. Namely, due to the flotation process complexity, i.e. large number of influencing variables, it is often necessary to combine different approaches in process modelling. Hence, it is not rare that kinetic and probabilistic models are mutually entwined and supplemented with the use of empirical expressions or constants in order to improve model adequacy.

4. Conclusion

Despite the fact that general flotation process principles are well known, the development of the quantitative predictive model, that would successfully be used to simulate industrial flotation plant operation is not a simple process. The difficulties originate from the complexity of many microprocesses and their mutual interactions influencing the final outcome of the mineral particles flotation.

However, since the thirties, much effort had been made to present the flotation process more adequately, resulting in large number of various models. These models, depending on approach, describe flotation process at the macro and micro level, and can be based on the classical mathematical equations or soft computing expressions.

Among the classical mathematical models – empirical, probabilistic, kinetic and population-balance models are the most often defined separate categories.

Empirical models are based on the experience data and they are, by the rule, related to a specific flotation plant, while probabilistic models take into account the probability of different subprocesses within the flotation system. The development of kinetic models is usually associated with the assumption that flotation process is performed according to first-order kinetics, while the population-balance models consider the kinetic processes in the flotation system by classification of mineral particles into pre-defined groups.

It is, however, important to emphasize that mentioned classification should not be considered very strict, because different modelling approaches are mutually entwined and supplemented for the purpose of better mathematical description of flotation concentration.

Acknowledgments

This investigation was conducted under the Project TR 33007 “Implementation of the modern technical, technological and ecological design solutions in the existing production systems of the Copper Mine Bor and Copper Mine Majdanpek” funded by the Ministry of Education, Science and Technological Development of the Republic of Serbia.

References

- Ali S., 2007. *Mathematical models for the efficiency of flotation process for North Waziristan copper*. PhD Thesis, University of education Lahore, Pakistan, 167 p.
- Bakker C.W., Meyer C.J., Deglon D.A., 2010. *The development of a cavern model for mechanical flotation cells*. Minerals Engineering, 23, p. 968-972.
- Bloom F., Heindel T.J., 1997. *Mathematical Modelling of the Flotation Deinking Process*. Mathematical and Computer Modelling, Vol. 25, No. 5, p. 13-58.
- Brożek M., Młynarczykowska A., 2007. *Analysis of kinetics models of batch Flotation*. Physicochemical Problems of Mineral Processing (Fizykochemiczne Problemy Mineralurgii), Vol. 41, p. 51-65.
- Brożek M., Młynarczykowska A., 2012. *The distribution of air bubble size in the pneumo-mechanical flotation machine*. Archives of Mining Sciences, Vol. 57, No. 3, p. 729-740.
- Casali A., Gonzalez G., Agosto H., Vallebuona G., 2002. *Dynamic simulator of a rougher flotation circuit for a copper sulphide ore*. Minerals Engineering, 15, p. 253-262.
- Çilek E.C., 2002. *Application of neural networks to predict locked cycle flotation test results*. Minerals Engineering, 15, p. 1095-1104.
- Ćalić N., 1990. *Teorijski osnovi pripreme mineralnih sirovina*. Faculty of Mining and Geology, University of Belgrade, 496 p. (In Serbian).
- Deglon D.A., Sawyerr F., O'Connor C.T., 1999. *A model to relate the flotation rate constant and the bubble surface area flux in mechanical flotation cells*. Minerals Engineering, Vol. 12, No. 6, p. 599-608.
- Dehghani F., Ranjbar G., Rezai B., 2011. *The Effect of the Shape of Silica Particles Ground by Ball Mill on their Flotation Kinetics*. American Journal of Scientific Research, Iss. 29, p. 33-40.
- Drzymała J., 2007. *Mineral Processing: Foundations of theory and practice of minerallurgy*. Wrocław University of Technology, 508 p.
- Duan J., Fornasiero D., Ralston J., 2003. *Calculation of the flotation rate constant of chalcopyrite particles in an ore*. International Journal of Mineral Processing, 72, p. 227-237.
- Faulkner B.P., 1966. *Computer control improves metallurgy at Tennessee copper flotation*. Plan Mining Engineering, Vol. 18, p. 53-57.
- Ferreira J.P., Loveday B.K., 2000. *An improved model for simulation of flotation circuits*. Minerals Engineering, Vol. 13, No. 14-15, p. 1441-1453.
- Fichera M.A., Chudacek M.W., 1992. *Batch cell flotation models – A review*. Minerals Engineering, Vol. 5, Iss. 1, p. 41-55.
- Garcia Zuñiga H., 1935. *The efficiency obtained by flotation is an exponential function of time*. Boletín Minero, Sociedad Nacional de Minería, Santiago, Chile, 47, p. 83-86.
- Gorain B.K., Franzidis J.-P., Manlapig E.V., 1999. *The empirical prediction of bubble surface area flux in mechanical flotation cells from cell design and operating data*. Minerals Engineering, Vol. 12, No. 3, p. 309-322.

- Harris C.C., 1978. *Multiphase models of flotation machine behaviour*. International Journal of Mineral Processing, Vol. 5, Iss. 2, p. 107-129.
- Harris M.C., Runge K.C., Whiten W.J., Morrison R.D., 2002. *JKSimFloat as a practical tool for flotation process design and optimization*. Mineral Processing Plant Design, Practice and Control, Vol. 1 (Edited by A.L. Mular, D.N. Halbe and D.J. Barrat), p. 461-478.
- Hay M.P., 2008. *Optimising froth condition and recovery for a nickel ore*, Minerals Engineering, 21, p. 861-872.
- Herbst J.A., Harris M.C., 2007. *Modeling and simulation of industrial flotation processes*. Froth Flotation: A Century of Innovation (Edited by M.C. Fuerstenau, G.J. Jameson, R.H. Yoon), Publisher: SME, p. 757-777.
- Herbst J.A., Flintoff B., 2012. *Recent Advances in Modeling, Simulation, and Control of Mineral Processing Operations*. In: Separation Technologies for Minerals, Coal, and Earth Resources (Edited by C.A. Young and G.H. Luttrell), Publisher: SME, p. 667-680.
- Hernández F., Calero M., 1996. *Flotation rate of celestite and calcite*. Chemical Engineering Science, Vol. 51, No. 1, p. 119-125.
- Hernández F., Calero M., 2001. *Froth flotation: kinetic models based on chemical analogy*. Chemical Engineering and Processing 40, p. 269-275.
- Hodouin D., 2011. *Methods for automatic control, observation, and optimization in mineral processing plants*. Journal of Process Control, 21, p. 211-225.
- Kalinowski K., Kaula R., 2013. *Verification of flotation kinetics model for triangular distribution of density function of flotability of coal particles*. Archives of Mining Sciences, Vol. 58, No. 4, p. 1279-1287.
- Kelsall D.F., 1961. *Application of probability in the assessment of flotation systems*. Transactions of the Institution of Mining and Metallurgy, Vol. 70, p. 191-204.
- King R.P., 2001. *Modeling and Simulation of Mineral Processing Systems*. Publisher: Butterworth-Heinemann, Oxford, Great Britain, 403 p.
- Kirjavainen V.M., 1989. *Application of a probability model for the entrainment of hydrophilic particles in froth flotation*. International Journal of Mineral Processing, Vol. 27, Iss. 1-2, p. 63-74.
- Koh P.T.L., Schwarz M.P., 2006. *CFD modelling of bubble-particle attachments in flotation cells*. Minerals Engineering, 19, p. 619-626.
- Koh P.T.L., Schwarz M.P., 2008. *Modelling attachment rates of multi-sized bubbles with particles in a flotation cell*. Minerals Engineering, 21, p. 989-993.
- Kuopaniemi H., Suorsa T., Dahl O., Niinimäki J., 2000. *A model of conditioning in the flotation of a mixture of pyrite and chalcopyrite ores*. International Journal of Mineral Processing, 59, p. 327-338.
- Laurila H., Karesvuori J., Tiili O., 2002. *Strategies for Instrumentation and Control of Flotation Circuits*. Mineral Processing Plant Design. Practice and Control, Vol. 2 (Edited by A.L. Mular, D.N. Halbe and D.J. Barrat), p. 2174-2195.
- Li Y., Zhao W., Gui X., Zhang X., 2013. *Flotation kinetics and separation selectivity of coal size fractions*. Physicochemical Problems of Mineral Processing, 49 (2), p. 387-395.
- Lynch A.J., Johnson N.W., Manlapig E.V., Thorne C.G., 1981. *Mineral and Coal Flotation Circuits - Their simulation and Control*. Publisher: Elsevier, 290 p.
- Maldonado M.A., 2010. *Advances in estimation and control for flotation columns*. PhD Thesis, Faculté des sciences et de génie, Université Laval, Québec, Canada, 175 p.
- Marais C., Aldrich C., 2011. *The estimation of platinum flotation grade from froth image features by using artificial neural networks*. The Journal of The Southern African Institute of Mining and Metallurgy, Vol. 111, p. 81-85.
- Milošević S., 1994. *Flotacijska koncentracija – Teorijske osnove flotiranja*. Technical Faculty in Bor, University of Belgrade, 211 p. (In Serbian).
- Miljanović I., 2008. *Fazi logičko upravljanje procesima u pripremi mineralnih sirovina*. Faculty of Mining and Geology, University of Belgrade, 161 p. (In Serbian).
- Mohammed A.A., 2007. *Removal of Emulsified Paraffine from Water: Effect of Bubble Size and Particle Size on Kinetic of Flotation*, Iraqi Journal of Chemical and Petroleum Engineering, Vol. 8, No. 3, p. 1-5.
- Moolman D.W., Aldrich C., Van Deventer J.S.J., 1995. *The monitoring of froth surfaces on industrial flotation plants using connectionist image processing techniques*. Minerals Engineering, Vol. 8, Iss. 1/2, p. 23-30.

- Nakhaei F., Mosavi M.R., Sam A., Vaghei Y., 2012. *Recovery and grade accurate prediction of pilot plant flotation column concentrate: Neural network and statistical techniques*. International Journal of Mineral Processing, 110-111, p.140-154.
- Nakhaei F., Mosavi M.R., Sam A., 2013. *Recovery and grade prediction of pilot plant flotation column concentrate by a hybrid neural genetic algorithm*. International Journal of Mining Science and Technology, 23, p. 69-77.
- Natarajan R., Nirdosh I., 2006. *A Comparative Study of Kinetics of Flotation of a Copper-Nickel Ore by N-Hydrocinnamoyl-N-Phenylhydroxylamine (HCNPHA) Vis-À-Vis Potassium Amyl Xanthate (PAX)*. Proceedings of the International Seminar on Mineral Processing Technology, Chennai, India, p. 236-242.
- Nguyen A.V., Ralston J., Schulze H.J., 1998. *On modelling of bubble-particle attachment probability in flotation*. International Journal of Mineral Processing, 53, p. 225-249.
- Nguyen A.V., 1998. *Particle-bubble encounter probability with mobile bubble surfaces*. International Journal of Mineral Processing, Vol. 55, Iss. 2, p. 73-86.
- Oproiu G., Lacatusu I., Stoica L., 2009. *Examination of Kinetic Flotation Process for Two Experimental Cu(II) and Ni(II) – α -benzoinoxime Systems, Based on Kinetic Literature Models*. Chemistry Magazine (Revista de Chimie), Vol. 60 (6), p. 641-645.
- Pérez-Correa R., González G., Casali A., Cipriano A., Barrer R., Zavala E., 1998. *Dynamic modelling and advanced multivariable control of conventional flotation circuits*. Minerals Engineering, Vol. 11, No. 4, p. 333-346.
- Pitt J.C., 1968. *The development of system for continuous optimal control of flotation plants*. In: Computer Systems Dynamics and Automatic Control in Basic Industries, I.F.R.C Symposium, Sydney, p. 165-171.
- Polat M., Chander S., 2000. *First-order flotation kinetics models and methods for estimation of the true distribution of flotation rate constants*. International Journal of Mineral Processing, Vol. 58, p. 145-166.
- Rahman R.M., Ata S., Jameson G.J., 2012. *The effect of flotation variables on the recovery of different particle size fractions in the froth and the pulp*. International Journal of Mineral Processing, Vol. 106-109, p. 70-77.
- Rath S.S., Sahoo H., Das B., 2013. *Optimization of flotation variables for the recovery of hematite particles from BHO ore*. International Journal of Minerals, Metallurgy and Materials, Vol. 20, No. 7, p. 605-611.
- Rojas D., Cipriano A., 2011. *Model based predictive control of a rougher flotation circuit considering grade estimation in intermediate cells*. Dyna Vol.78, No. 166, p. 29-37.
- Runge K.C., Franzidis J.P., Manlapig E.V., 2003a. *A study of the flotation characteristics of different mineralogical classes in different streams of an industrial circuit*. Proceedings of XXII International Mineral Processing Congress, 29 September – 3 October 2003, Cape Town, South Africa, p. 962-972.
- Runge K.C., Franzidis J.P., Manlapig E.V., Harris M.C., 2003b. *Structuring a flotation model for robust prediction of flotation circuit performance*. Proceedings of XXII International Mineral Processing Congress, 29 September – 3 October 2003, Cape Town, South Africa, p. 973-984.
- Saleh A.M., 2010. *A study on the performance of second order models and two phase models in iron ore flotation*. Physicochemical Problems of Mineral Processing, Vol. 44, p. 215-230.
- Savassi O.N., Alexander D.J., Franzidis J.P., Manlapig E.V., 1998. *An empirical model for entrainment in industrial flotation plants*. Minerals Engineering, Vol. 11, No. 3, p. 243-256.
- Sawyer F., Deglon D.A., O'Connor C.T., 1998. *Prediction of bubble size distribution in mechanical flotation cells*. The Journal of The South African Institute of Mining and Metallurgy, 98 (4), p. 179-185.
- Sbarbaro D., Maldonado M., Cipriano A., 2008. *A two level hierarchical control structure for optimizing a rougher flotation circuit*. Proceedings of the 17th World Congress The International Federation of Automatic Control, Seoul, Korea, July 6-11, 2008, p. 11018-11022.
- Schulze H.J., 1993. *Flotation as a heterocoagulation process: Possibilities of calculating the probability of flotation*. In: Coagulation and Flocculation: Theory and Applications (Edited by B. Dobiáš), p. 321-353.
- Schulze H.J., Stöckelhuber W., 2005. *Flotation as a Heterocoagulation Process: Possibilities of Calculating the Probability of the Microprocesses, Rupture of the Intervening Thin Liquid Film, and Progress in Modeling of the Overall Process*. In: Coagulation and Flocculation, (Edited by H. Stechemesser and B. Dobiáš), p. 455-517.
- Schumann R., 1942. *Flotation Kinetics. Part 1. Methods for Steady-State Study of Flotation Problems*. Journal of Physical Chemistry, Vol. 46, p. 891-902.
- Shammas N.K., Bennett G.F., 2010. *Principles of Air Flotation Technology*. In: Flotation Technology (Edited by L.K. Wang, N.K. Shammas, W.A. Selke, D.B. Aulenbach), Chapter 1, p. 1-47.

- Shean B.J., Cilliers J.J., 2011. *A review of froth flotation control*. International Journal of Mineral Processing, 100, p. 57-71.
- Sherrell I.M., 2004. *Development of a Flotation Rate Equation from First Principles under Turbulent Flow Conditions*. PhD Thesis, Virginia Polytechnic Institute and State University, Blacksburg, 95 p.
- Somasundaran P., Lin I.J., 1973. *Method for Evaluating Flotation Kinetics Parameters*. Transactions of SME, Vol. 254, p. 181-184.
- Sosa-Blanco C., Hodouin D., Bazin C., Lara-Valenzuela C., Salazar J., 1999. *Integrated simulation of grinding and flotation*. Application to a lead-silver ore, Minerals Engineering, Vol. 12, No. 8, p. 949-967.
- Sripriya R., Rao P.V.T., Choudhury B.R., 2003. *Optimisation of operating variables of fine coal flotation using a combination of modified flotation parameters and statistical techniques*. International Journal of Mineral Processing 68, p. 109-127.
- Tsatouhas G., Grano S.R., Vera M., 2006. *Case studies on the performance and characterisation of the froth phase in industrial flotation circuits*. Minerals Engineering, 19, p. 774-783.
- Uçurum M., Bayat O., 2007. *Effects of operating variables on modified flotation parameters in the mineral separation*. Separation and Purification Technology, 55, p. 173-181.
- Vera M.A., Mathe Z.T., Franzidis J.-P., Harris M.C., Manlapig E.V., O'Connor C.T., 2002. *The modelling of froth zone recovery in batch and continuously operated laboratory flotation cells*. International Journal of Mineral Processing, Vol. 64 p. 135-151.
- Vieira S.M., Sousa J.M.C., Durão F.O., 2005. *Fuzzy modelling strategies applied to a column flotation process*. Minerals Engineering 18, p. 725-729.
- Villar R. del, Desbiens A., Maldonado M., Bouchard J., 2010. *Automatic Control of Flotation Columns*. In: Advanced Control and Supervision of Mineral Processing Plants (Edited by D. Sbárbaro, R. del Villar), Chapter 6, p. 249-286.
- Welsby S.D.D., Vianna S.M.S.M., Franzidis J.-P., 2010. *Assigning physical significance to floatability components*. International Journal of Mineral Processing, 97, p. 59-67.
- Woodburn E.T., 1970. *Mathematical modelling of flotation process*. Minerals Science and Engineering, Vol. 2, p. 3-17.
- Xian-ping L., Xue-kun T., Li-ping H., Li-ying L., 2011. *Effects of size distribution on flotation kinetics of Chalcopyrite*. 2011 International Conference on Environment Science and Engineering IPCBEE, Vol. 8, IACSIT Press, Singapore, p. 81-85.
- Yianatos J.B., 1989. *Column flotation: modeling and technology*. In Proceedings of International Colloquium: Developments in Froth Flotation, Vol. 2, 3-4 August 1989, Cape Town, South Africa, p. 1-30.
- Yianatos J.B., Bergh L.G., Díaz F., Rodríguez J., 2005a. *Mixing characteristics of industrial flotation equipment*. Chemical Engineering Science, 60, p. 2273-2282.
- Yianatos J., Bucarey R., Larenas J., Henríquez F., Torres L., 2005b. *Collection zone kinetic model for industrial flotation columns*. Minerals Engineering, 18, p.1373-1377.
- Yianatos J.B., Henríquez F.D., 2006. *Short-cut method for flotation rates modelling of industrial flotation banks*. Minerals Engineering, 19, p. 1336-1340.
- Yianatos J.B., Henríquez F.H., Oroz A.G., 2006. *Characterization of large size flotation cells*. Minerals Engineering, 19, p. 531-538.
- Yianatos J.B., 2007. *Fluid flow and kinetic modelling in flotation related processes columns and mechanically agitated cells – a review*. Trans IChemE, Part A, Chemical Engineering Research and Design, Vol. 85 (A12), p. 1591-1603.
- Yianatos J., Contreras F., 2010. *Particle entrainment model for industrial flotation cells*. Powder Technology, 197, p. 260-267.
- Yianatos J., Bergh L., Vinnett L., Contreras F., Díaz F., 2010. *Flotation rate distribution in the collection zone of industrial cells*. Minerals Engineering, 23, p. 1030-1035.
- Yianatos J., Carrasco C., Bergh L., Vinnett L., Torres C., 2012. *Modelling and simulation of rougher flotation circuits*. International Journal of Mineral Processing, Vol. 112-113, p. 63-70.
- Zhang J.G., 1989. *Factors affecting the kinetics of froth flotation*. PhD thesis, Department of Mining and Mineral Engineering, University of Leeds, Great Britain, 41 p.